

THE STATE OF DELAWARE



DEPARTMENT OF TRANSPORTATION  
MAINTENANCE AND OPERATIONS  
CONSTRUCTION PLANS AND SPECIFICATIONS FOR

COMMUNITY TRANSPORTATION FUND, WILMINGTON, 2025

CONTRACT NUMBER - T202503120

UNIFIER PROJECT ID – 2025-00065

FEDERAL AID NUMBER - NONE

COUNTY: NEW CASTLE

PLANS PREPARED BY: *T. H.*  
DESIGNER

*Nathan S. Draper*

January 29, 2025

DELDOT – PUBLIC WORKS ENGINEER/PM II  
MAINTENANCE AND OPERATIONS - (CAD)

DATE



THIS SEAL APPLIES TO ALL SHEETS  
BEARING THE "CAD" SECTION  
DESIGNATION

APPROVED FOR ADVERTISEMENT

*Anne Brown*

2/4/2025

DIRECTOR OF MAINTENANCE AND OPERATIONS

DATE

---

DEPARTMENT OF TRANSPORTATION

---

CONTRACT NUMBER- T202503120

(CAD) PAGE 2 OF 84

---

CONTRACT IS FOR VARIOUS LOCATIONS THROUGHOUT NEW CASTLE COUNTY.

---

LOCATION MAP

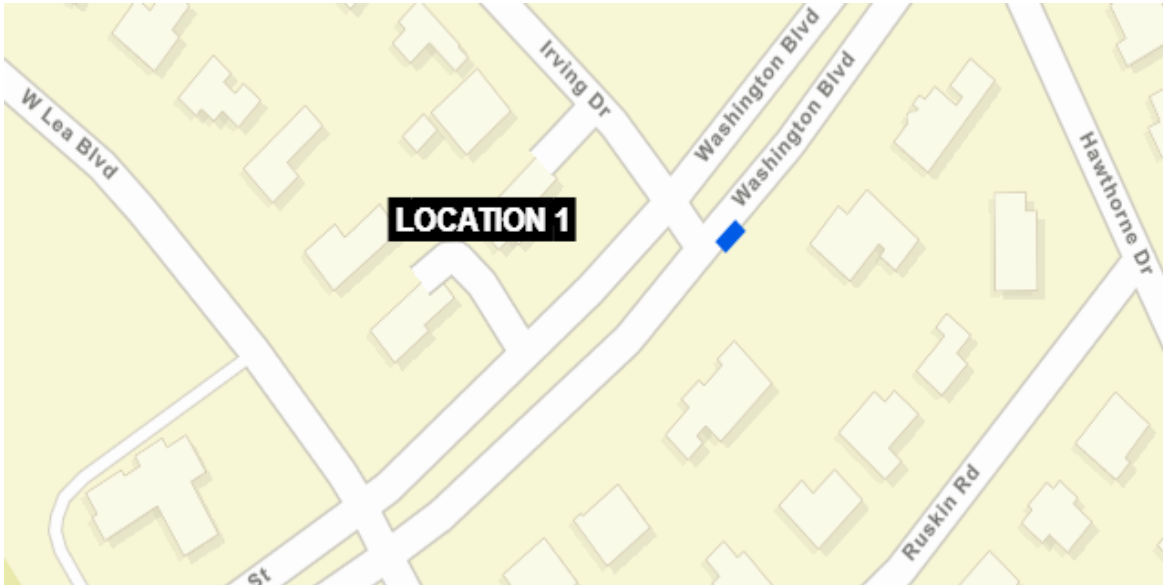

---

DEPARTMENT OF TRANSPORTATION

---

CONTRACT NUMBER- T202503120

(CAD) PAGE 3 OF 84

---

CONTRACT IS FOR VARIOUS LOCATIONS THROUGHOUT NEW CASTLE COUNTY.

---

LOCATION MAP

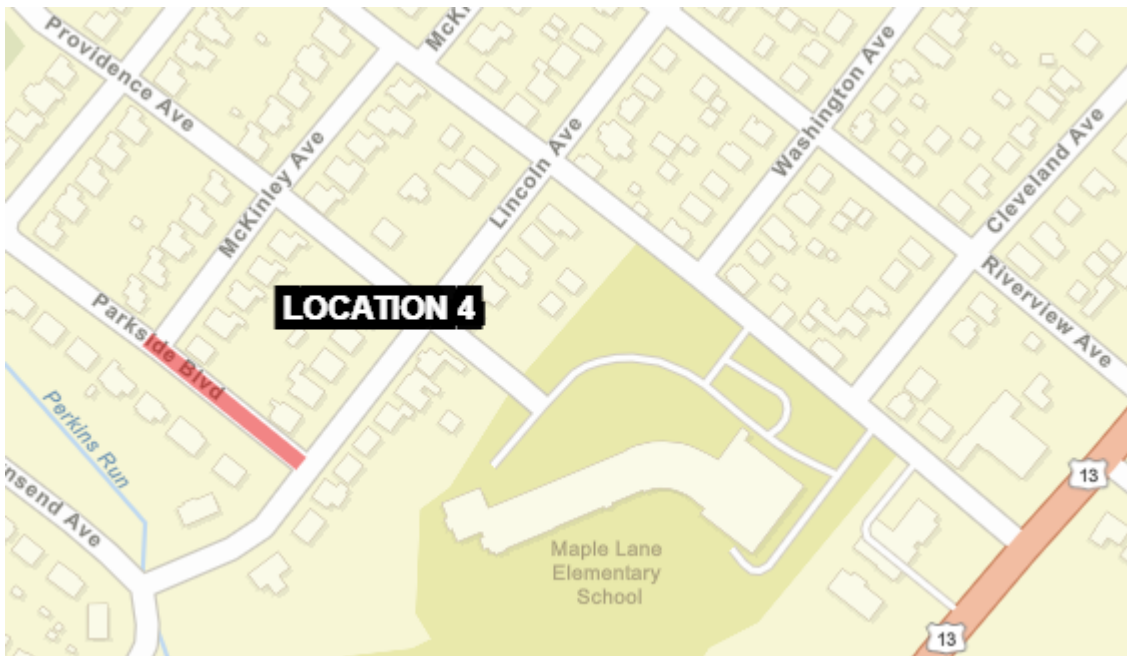

---

DEPARTMENT OF TRANSPORTATION

---

CONTRACT NUMBER- T202503120

(CAD) PAGE 4 OF 84

---

CONTRACT IS FOR VARIOUS LOCATIONS THROUGHOUT NEW CASTLE COUNTY.

---

LOCATION MAP

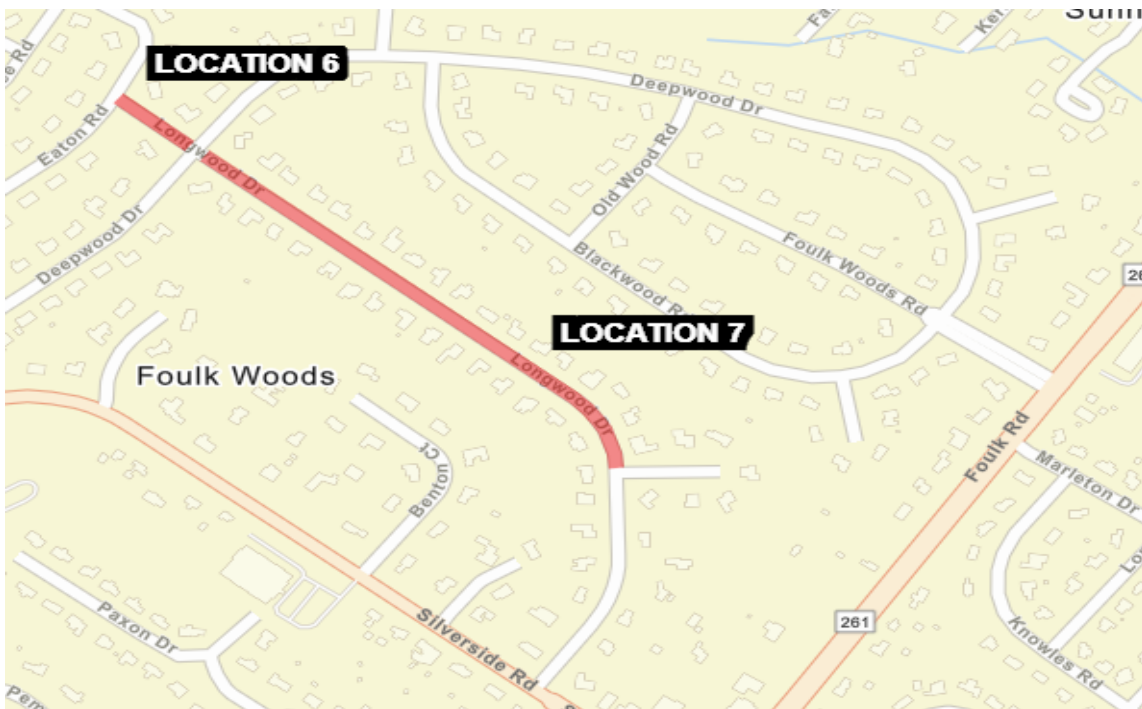

---

DEPARTMENT OF TRANSPORTATION

---

CONTRACT NUMBER- T202503120

(CAD) PAGE 5 OF 84

---

CONTRACT IS FOR VARIOUS LOCATIONS THROUGHOUT NEW CASTLE COUNTY.

---

LOCATION MAP

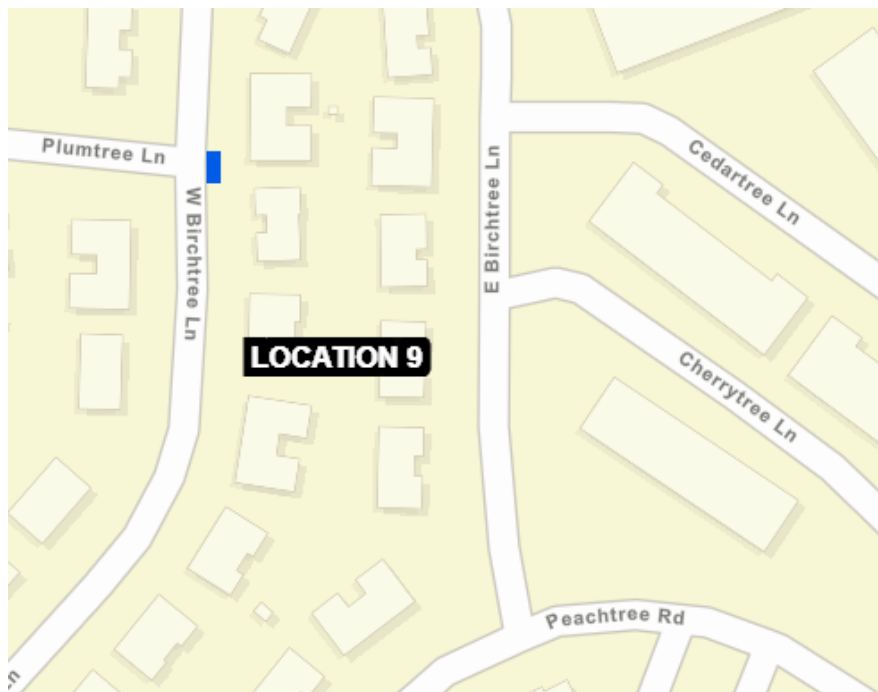
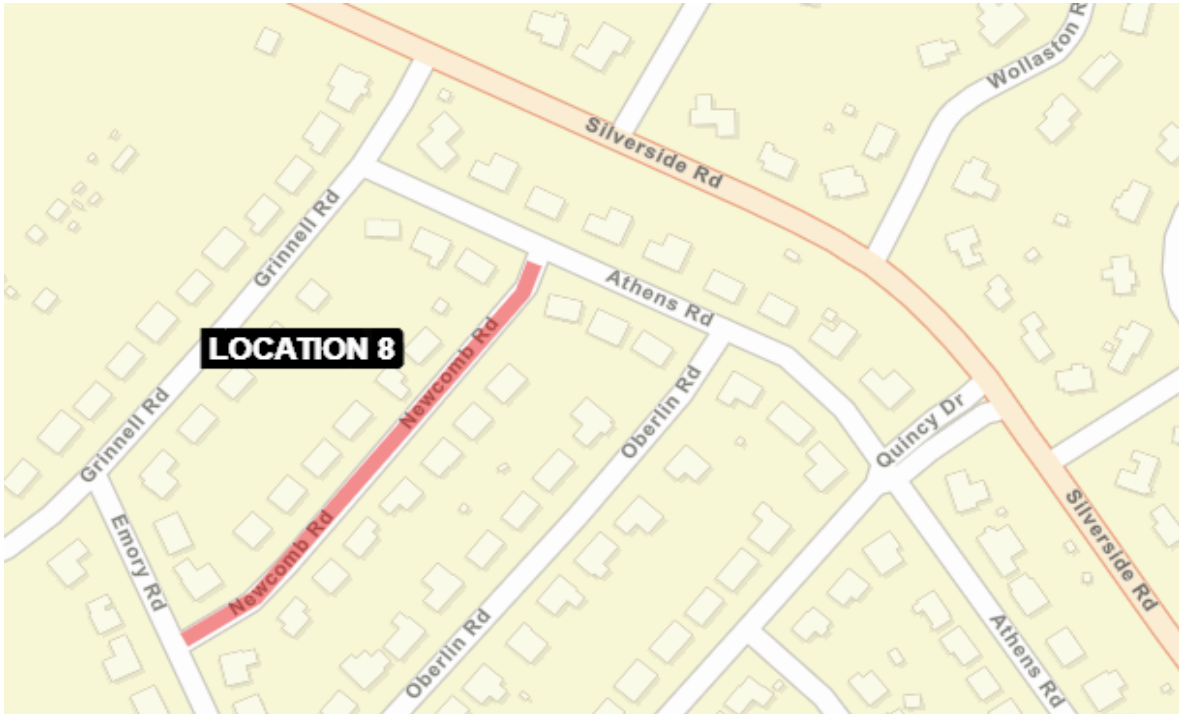

CONTRACT IS FOR VARIOUS LOCATIONS THROUGHOUT NEW CASTLE COUNTY.

LOCATION MAP

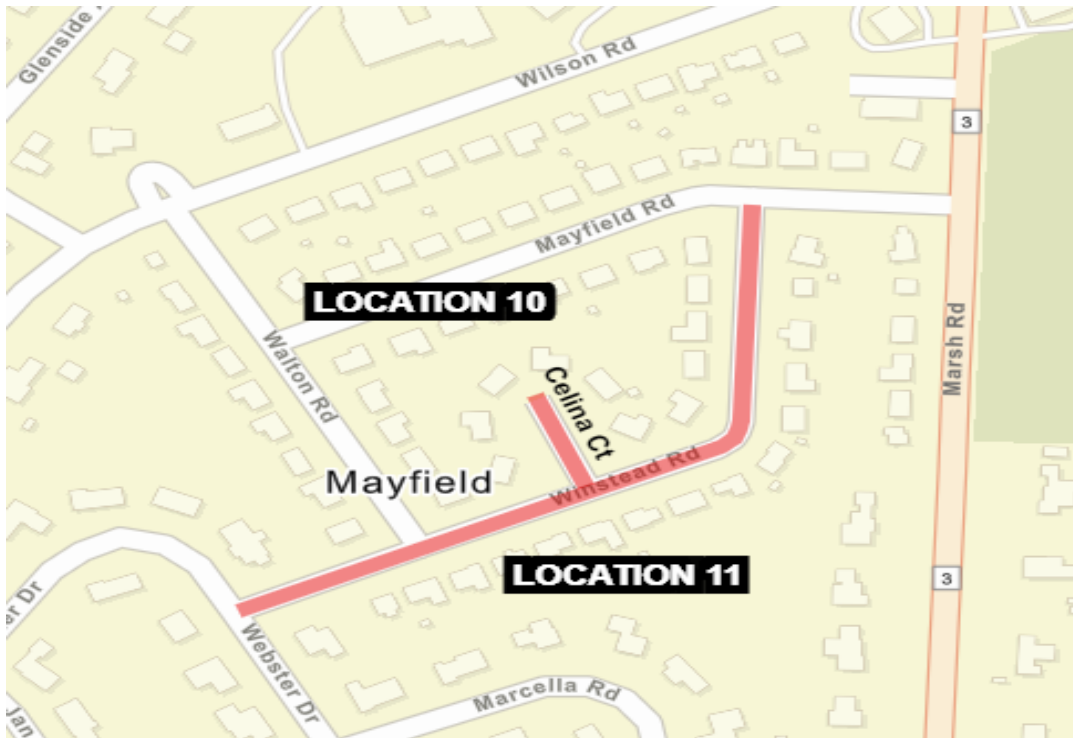

---

DEPARTMENT OF TRANSPORTATION

---

CONTRACT NUMBER- T202503120

(CAD) PAGE 7 OF 84

---

CONTRACT IS FOR VARIOUS LOCATIONS THROUGHOUT NEW CASTLE COUNTY.

---

LOCATION MAP

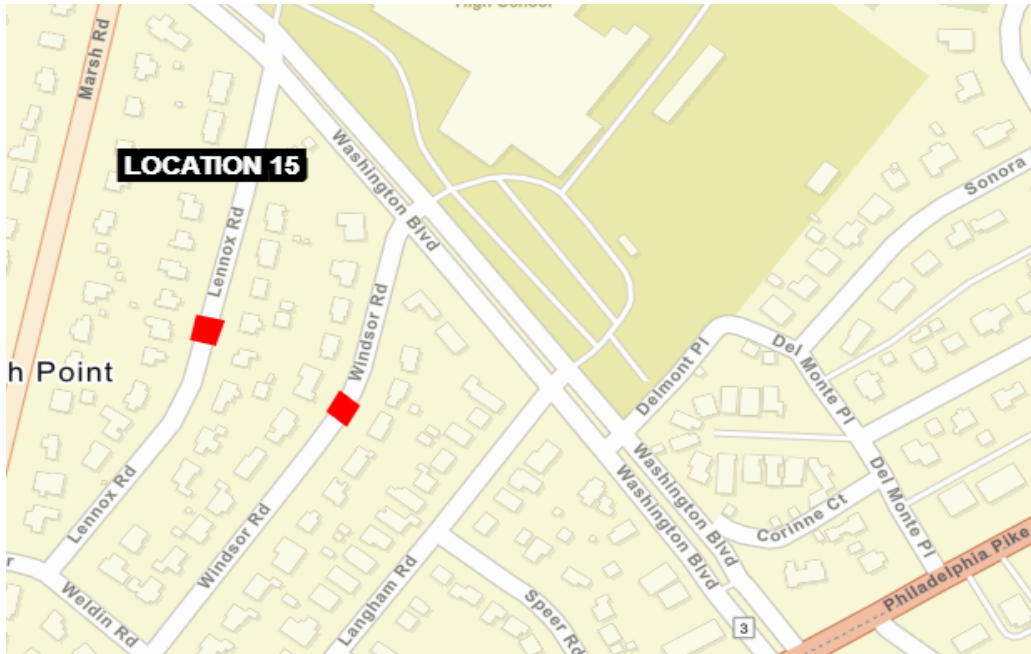

---

DEPARTMENT OF TRANSPORTATION

---

CONTRACT NUMBER- T202503120

(CAD) PAGE 8 OF 84

---

CONTRACT IS FOR VARIOUS LOCATIONS THROUGHOUT NEW CASTLE COUNTY.

---

LOCATION MAP



---

DEPARTMENT OF TRANSPORTATION

---

CONTRACT NUMBER- T202503120

(CAD) PAGE 9 OF 84

---

CONTRACT IS FOR VARIOUS LOCATIONS THROUGHOUT NEW CASTLE COUNTY.

---

LOCATION MAP

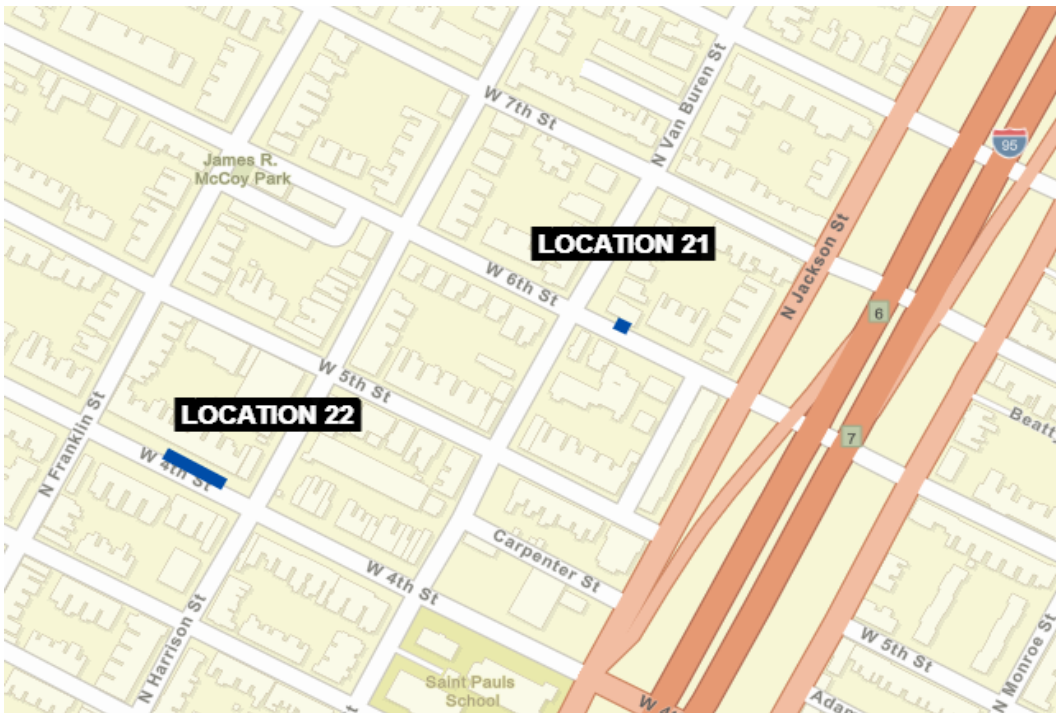

---

DEPARTMENT OF TRANSPORTATION

---

CONTRACT NUMBER- T202503120

(CAD) PAGE 10 OF 84

---

CONTRACT IS FOR VARIOUS LOCATIONS THROUGHOUT NEW CASTLE COUNTY.

---

LOCATION MAP

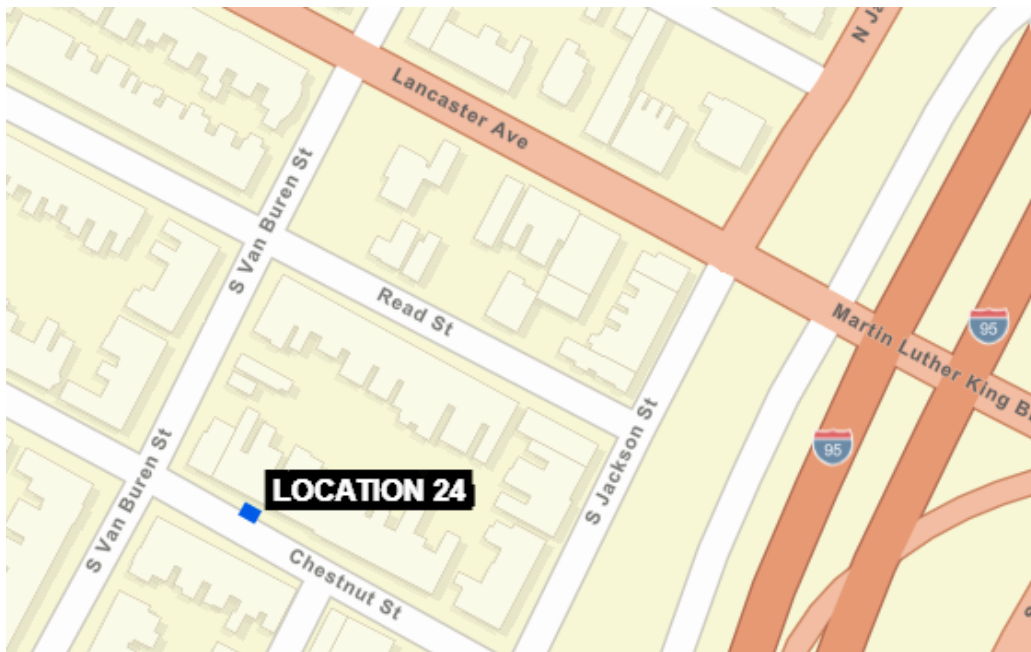

CONTRACT IS FOR VARIOUS LOCATIONS THROUGHOUT NEW CASTLE COUNTY.

LOCATION MAP



---

DEPARTMENT OF TRANSPORTATION

---

CONTRACT NUMBER- T202503120

(CAD) PAGE 12 OF 84

---

CONTRACT IS FOR VARIOUS LOCATIONS THROUGHOUT NEW CASTLE COUNTY.

---

LOCATION MAP



---

DEPARTMENT OF TRANSPORTATION

---

CONTRACT NUMBER- T202503120

(CAD) PAGE 13 OF 84

---

CONTRACT IS FOR VARIOUS LOCATIONS THROUGHOUT NEW CASTLE COUNTY.

---

LOCATION MAP



---

DEPARTMENT OF TRANSPORTATION

---

CONTRACT NUMBER- T202503120

(CAD) PAGE 14 OF 84

---

CONTRACT IS FOR VARIOUS LOCATIONS THROUGHOUT NEW CASTLE COUNTY.

---

LOCATION MAP

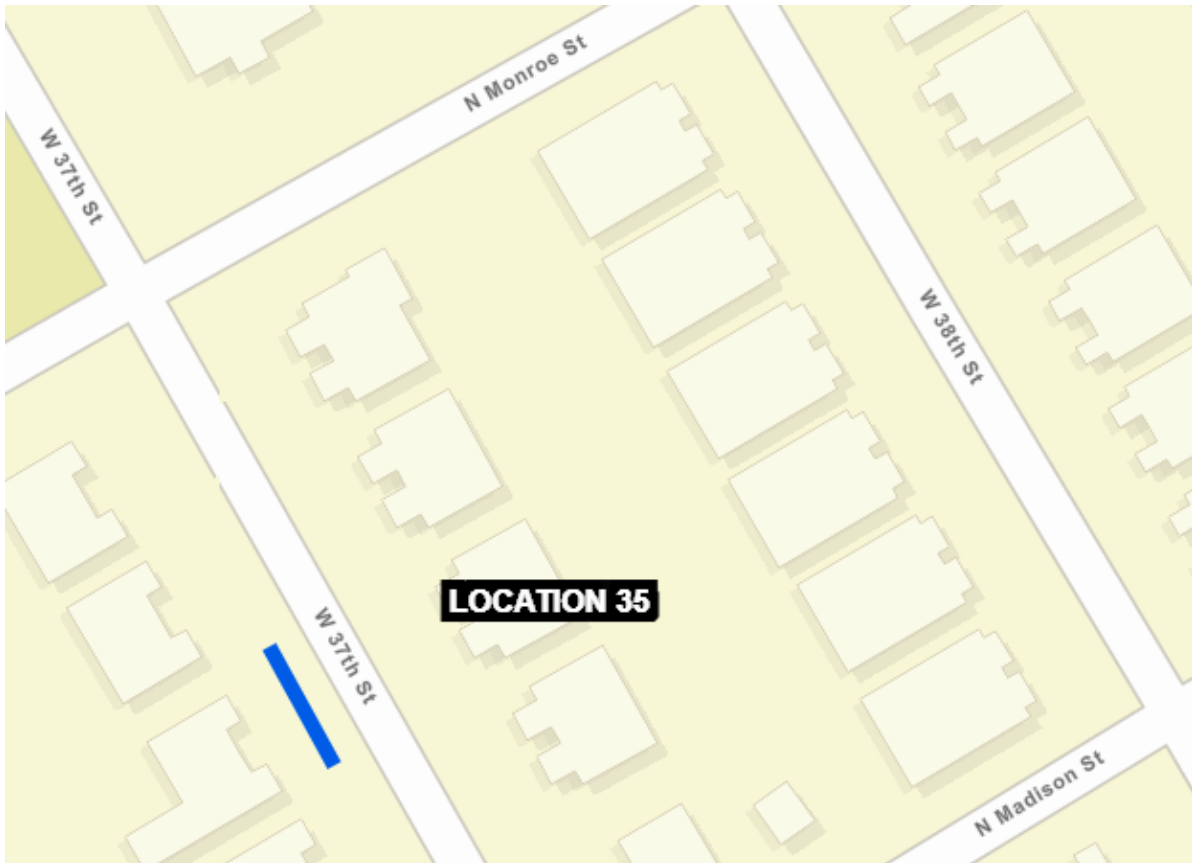

---

DEPARTMENT OF TRANSPORTATION

---

CONTRACT NUMBER- T202503120

(CAD) PAGE 15 OF 84

---

CONTRACT IS FOR VARIOUS LOCATIONS THROUGHOUT NEW CASTLE COUNTY.

---

LOCATION MAP

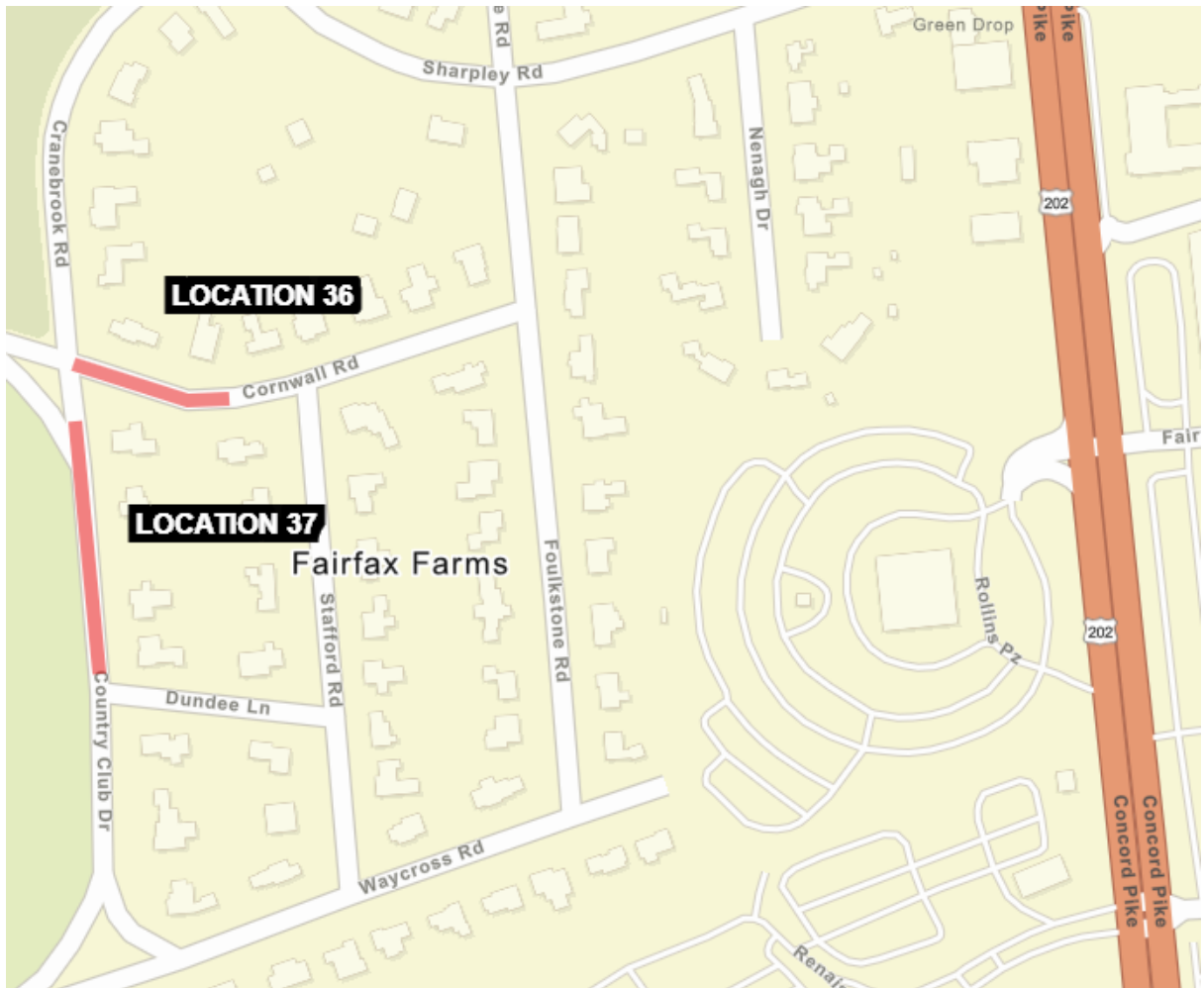

GENERAL CONTRACT PLAN NOTES

**SECTION 100**

1. THIS PROJECT IS TO BE CONSTRUCTED IN ACCORDANCE WITH THE DELAWARE DEPARTMENT OF TRANSPORTATION STANDARD SPECIFICATIONS FOR ROAD AND BRIDGE CONSTRUCTION DATED JANUARY 2024 AND THE DELAWARE DEPARTMENT OF TRANSPORTATION STANDARD CONSTRUCTION DETAILS DATED 2024, INCLUDING ALL REVISIONS UP TO THE DATE OF ADVERTISEMENT.

2. THE PURPOSE OF THIS CONTRACT IS TO MAKE GENERAL IMPROVEMENTS TO ROADS AND/OR STREETS WITHIN THE DISTRICT HEREIN SPECIFIED. DEPENDING ON FUND AVAILABILITY, THE DEPARTMENT RESERVES THE RIGHT TO ADD OR DELETE LOCATIONS AND/OR QUANTITIES FOR THIS CONTRACT. SUCH ADDITIONS OR DELETIONS SHALL NOT BE CAUSE FOR AN INCREASE OR DECREASE IN ANY CONTRACT UNIT BID PRICES. NO ITEM PRICES ARE TO BE RENEGOTIATED DUE TO EITHER AN INCREASE OR DECREASE IN QUANTITY USAGE RESULTING FROM SAID ADDITIONS OR DELETIONS.

3. THE CONTRACTOR SHALL PROVIDE WRITTEN NOTICE TO RESIDENTS AND BUSINESSES AT LEAST 48 HOURS, BUT NO MORE THAN 96 HOURS, PRIOR TO ALL PHASES OF CONTRACT WORK INCLUDING BUT NOT LIMITED TO: SAWCUTTING FOR P.C.C. OPERATIONS, P.C.C. REMOVAL AND REPLACEMENT, PAVEMENT MILLING, AND PAVING. THIS NOTICE SHALL BE GIVEN TO ALL RESIDENTS AND BUSINESSES WHOSE PROPERTY IS ADJACENT TO THE STREET ON WHICH WORK IS TO BE PERFORMED. FAILURE TO GIVE PROPER NOTICE WILL RESULT IN A SUSPENSION OF WORK REQUIRING NOTICE, UNTIL PROPER NOTICE IS PROVIDED. UPON COMPLETION OF DISTRIBUTING WRITTEN NOTICES, THE CONTRACTOR SHALL IMMEDIATELY NOTIFY THE ENGINEER.

4. LOCATION LISTINGS INDICATE GENERAL LIMITS OF CONSTRUCTION, MAJOR TYPES OF IMPROVEMENTS, AND ESTIMATED QUANTITIES. DURING THE BIDDING PERIOD, ANY QUESTIONS PERTAINING TO LOCATIONS SHALL BE DIRECTED TO THE CONTRACT ADMINISTRATOR. AFTER THE AWARD, SUCH QUESTIONS SHALL BE REFERRED TO THE APPROPRIATE DISTRICT ENGINEER OR HIS REPRESENTATIVE.

5. THIS CONTRACT WILL HAVE CLEAR "START BY" DATE AND TIME ALLOCATED FOR COMPLETION. FAILURE TO COMPLETE THE CONTRACT IN THE SPECIFIED TIME SHALL CONSTITUTE "FAILURE TO PURSUE THE WORK" AND SUBJECTS THE CONTRACTOR TO LIQUIDATED DAMAGES AS OUTLINED IN SUBSECTION 108.8 OF THE STANDARD SPECIFICATIONS.

6. THE CONTRACTOR SHALL SUBMIT THE REQUIRED COPIES OF A DETAILED PROGRESS SCHEDULE (PSC) AS OUTLINED IN STANDARD SPECIFICATION 108.4 PRIOR TO THE PRECONSTRUCTION MEETING. DETAILS SHALL INCLUDE A DESCRIPTION OF EACH WORK ACTIVITY, THE PLANNED DAYS OF WORK, MULTIPLE CREWS OR SHIFTS, AND SCHEDULED WORKING HOURS. DURING THE CONTRACT, THE CONTRACTOR SHALL SUBMIT TWO-WEEK (OR AS REQUIRED) "LOOK AHEAD" SCHEDULES TO THE AREA ENGINEER/ MANAGER NO LATER THAN

---

**DEPARTMENT OF TRANSPORTATION**

---

**CONTRACT NUMBER- T202503120 CANAL  
COMMUNITY TRANSPORTATION FUND, WILMINGTON, 2025**

**(CAD) PAGE 17 OF 84**

---

**GENERAL CONTRACT PLAN NOTES**

NOON OF EACH THURSDAY. FAILURE TO COMPLY WILL RESULT IN A SUSPENSION OF ALL CONTRACT WORK WITH TIME CHARGES CONTINUING TO BE ASSESSED.

**ADDITIONAL WORK:**

7. THE DEPARTMENT RESERVES THE RIGHT TO INCREASE OR DECREASE THE QUANTITIES OF THE ITEMS SPECIFIED IN THIS CONTRACT. SUCH ADDITIONS SHALL NOT BE CAUSE FOR AN INCREASE OR DECREASE IN ANY CONTRACT UNIT BID PRICES AND/OR LUMP SUM ITEMS IF THE INCREASE IN QUANTITIES DOES NOT REQUIRE REMOBILZATON.

8. THE DEPARTMENT RESERVES THE RIGHT TO ADD LOCATONS TO THIS CONTRACT. SPECIFIC WORK WILL BE ASSIGNED BY THE DEPARTMENT VIA WORK ORDERS AND THE DEPARTMENT WILL MAKE EVERY ATTEMPT TO MINIMIZE THE DISTANCE BETWEEN SUCCESSIVE LOCATIONS. THE CONTRACTOR MAY SUBMIT A REQUEST FOR ADDITIONAL MOT AND MOBILIZATION IN CONJUNCTION WITH ADDED LOCATIONS. THIS REQUEST WILL BE CONSIDERED ON THE BASIS OF EACH ADDITIONAL LOCATION. THE REQUEST FOR INITIAL EXPENSE/MOBILIZATION SHALL NOT EXCEED THE AMOUNT OF THE BID PRICE FOR 763000, DIVIDED BY THE NUMBER OF ORIGINAL CONTRACT LOCATIONS. THE REQUEST FOR MOT SHALL NOT EXCEED THE AMOUNT OF THE BID PRICE FOR 801500, DIVIDED BY THE NUMBER OF ORIGINAL CONTRACT LOCATIONS. FOR OPEN END CONTRACTS WITHOUT ORIGINAL LOCATIONS, BID ITEMS 763544-763552 SHALL BE FULL COMPENSATION FOR MOBILIZATION AND MOT.

EACH WORK ORDER ISSUED WILL HAVE CLEAR "START BY" DATE AND TIME ALLOCATED TO COMPLETE SAID WORK ORDER. ONCE TIME (CALENDAR DAYS) HAS BEEN ASSIGNED TO A WORK ORDER AND ISSUED, THE CONTRACTOR HAS 2 BUSINESS DAYS, NOT INCLUDING THE DAY OF ISSUANCE, TO DISPUTE THE TIME QUANTITY AND PROVIDE ADDITIONAL BACKUP DOCUMENTATION FOR WHY THE TIME QUANTITY IS NOT SUFFICIENT. A DETAILED BREAKDOWN OF LABOR/MATERIALS/EQUIPMENT ALONG WITH THE CONTRACTORS TIME ESTIMATE WILL BE REQUIRED; THIS INFORMATION MUST BE RECEIVED BY THE DEPARTMENT BY THE END OF THE 2<sup>ND</sup> BUSINESS DAY OR THE DEPARMENT WILL CONSIDER THE CONTRACTOR IN AGREEMENT WITH THE TIME ESTIMATE. THE ENGINEER WILL EVALUATE ANY REQUEST FOR MODIFICATION TO THE TIME ESTIMATE AND AT THEIR SOLE DISCRETION DETERMINE IF ADDITIONAL TIME IS GRANTED. DISPUTING TIME QUANTITY DOES NOT CONSTITUTE A DELAY IN COMMENCEMENT OF A WORK ORDER. ISSUANCE OF EACH WORK ORDER CONSTITUTES THE NOTICE TO PROCEED WITH THE WORK DESCRIBED. FAILURE TO COMPLETE A WORK ORDER IN THE SPECIFIED TIME SHALL CONSTITUTE "FAILURE TO PURSUE THE WORK" AND SUBJECTS THE CONTRACTOR TO LIQUIDATED DAMAGES AS OUTLINED IN SUBSECTION 108. 9 OF THE STANDARD SPECIFICATIONS BASED ON THE TOTAL VALUE OF THAT PARTICULAR WORK ORDER.

UPON ISSUANCE OF EACH WORK ORDER, THE CONTRACTOR SHALL SUBMIT THE REQUIRED COPIES OF A DETAILED PROGRESS SCHEDULE AS OUTLINED IN STANDARD SPECIFICATION 108.4 WITHIN 5

**GENERAL CONTRACT PLAN NOTES**

CALENDAR DAYS OF THE ISSUANCE OF WORK ORDER. DURING THE CONTRACT, THE CONTRACTOR SHALL SUBMIT TWO-WEEK (OR AS REQUIRED) "LOOK AHEAD" SCHEDULES TO THE AREA ENGINEER NO LATER THAN NOON OF EACH THURSDAY. DETAILS SHALL INCLUDE A DESCRIPTION OF EACH WORK ACTIVITY, THE PLANNED DAYS OF WORK, MULTIPLE CREWS OR SHIFTS, AND SCHEDULED WORKING HOURS. FAILURE TO COMPLY WILL RESULT IN A SUSPENSION OF ALL CONTRACT WORK WITH TIME CHARGES CONTINUING TO BE ASSESSED. THE PROGRESS SCHEDULE MUST ALSO BE UPDATED AND SUBMITTED TO THE DEPARTMENT AS CHANGES OR DELAYS OCCUR IN THE CONTRACT.

**SECTION 400**

9. UNLESS SPECIFIED, OVERLAY WIDTHS SHALL MATCH EXISTING WIDTHS.

10. THE COST OF CLIPPING BACK THE EDGES OF THE ROADWAY, SHOULDERS, AND THE FIRST 3' OF UNPAVED DRIVEWAY ENTRANCES, PICKING UP AND DISPOSING OF WASTE AND EXCESS MATERIAL, AND CLEANING THE EXISTING PAVEMENT PRIOR TO AN OVERLAY SHALL BE INCIDENTAL TO SECTION 401XXX. PREPARING UNPAVED DRIVEWAY ENTRANCES BEYOND THE FIRST 3' SHALL BE PAID UNDER THE APPROPRIATE CONTRACT ITEMS: 202000 AND/OR 30100X.

11. ALL PAVING, INCLUDING TURN LANES AND INTERSECTIONS, IS TO BE COMPLETED CURB TO CURB WITHIN SEVEN (7) CALENDAR DAYS FROM THE TIME THE AREA WAS MILLED. THIS RESTRICTION APPLIES TO EACH DAYS PAVEMENT MILLING OPERATION, NOT AN ENTIRE PROJECT LOCATION. FAILURE TO COMPLY WILL RESULT IN A SUSPENSION OF ALL OTHER CONTRACT WORK WITH TIME CHARGES CONTINUING TO BE ASSESSED.

12. IN ADDITION TO ITEM 401506 SPEED HUMP BEING UTILIZED FOR NEW SPEED HUMPS, IT SHALL ALSO INCLUDE REMOVE AND REPLACE SPEED HUMPS. UNLESS NOTED OTHERWISE, SPEED HUMPS SHALL BE MEASURED AND REPLACED AT THE SAME HEIGHT PRIOR TO CONSTRUCTION BUT SHALL NOT EXCEED 4". ALL SIGNING AND STRIPING SHALL CONFORM TO THE LATEST EDITION OF THE DE MUTCD.

AT REMOVE AND REPLACE LOCATIONS, 401506 SHALL BE PAID AND THE REMOVAL SHALL BE INCIDENTAL TO THIS ITEM. SPEED HUMPS REMOVED AS PART OF THE MILLING/PAVING OPERATION, SCHEDULED TO BE PUT BACK, SHALL BE REPLACED WITHIN SEVEN (7) DAYS OF COMPLETION OF PAVING. FAILURE TO COMPLY WILL RESULT IN A SUSPENSION OF ALL OTHER CONTRACT WORK WITH TIME CHARGES CONTINUING TO BE ASSESSED. PAYMENT FOR THIS ITEM SHALL INCLUDE PERMANENT STRIPING AND DELINEATOR POSTS. IF PERMANENT STRIPING

**GENERAL CONTRACT PLAN NOTES**

CANNOT BE PLACED THE SAME DAY AS THE SPEED HUMP PLACEMENT, TEMPORARY STRIPING SHALL BE APPLIED THE SAME DAY.

13. PAVING WILL INCLUDE INTERSECTING STREETS FROM P.C. TO P.C.: MILLING AND PAVING OF INTERSECTING STREETS WILL NOT BE CONSIDERED FOR ENTRANCE, DRIVEWAY AND INTERSECTING STREET PAVEMENT SURCHARGE, NOR WILL DRIVEWAYS AND ENTRANCES.

14. FOR BITUMINOUS CONCRETE PATCH:

- FOR DRIVEWAY APRONS (BEHIND CURB) PLACE 2 LIFTS OF 2" BITUMINOUS CONCRETE TYPE C.
- FOR FINISHED PATCHES IN FRONT OF CURB, PLACE 2 LIFTS OF 2" BITUMINOUS CONCRETE TYPE C.
- FOR TEMPORARY PATCHES IN FRONT OF CURB, PLACE 2 LIFTS OF 2" OF BITUMINOUS CONCRETE TYPE C OR AS DIRECTED BY THE AREA ENGINEER.
- THE ENGINEER MAY CHANGE TYPE OF BITUMINOUS CONCRETE AND DEPTHS AT THEIR DISCRETION.

**SECTION 500**

15. ITEM 501001 PCC PAVEMENT, 8" IS DESIGNATED FOR NOW-DEFUNCT ITEM 701004 PCC VALLEY GUTTER-8". WHEN REPLACING VALLEY GUTTERS, PLEASE REFER TO CONTRACT PLAN DETAILS. DOWEL BARS, WIRE MESH REINFORCEMENT, BITUMINOUS SEAL, AND EXPANSION, PCC SAWCUTS, AND GABC UNDER THE PCC ARE INCIDENTAL TO VALLEY GUTTER ITEM (501001).

**SECTION 600**

16. DRAINAGE INLET GRATES ADJACENT TO THE ROAD, WITHIN THE PROJECT LIMITS, WHICH ARE NOT TYPE 1 SHALL BE REPLACED WITHIN 7 DAYS OF PAVING. THE NEED FOR ANY GRATE MODIFICATIONS OR FOR NEW FRAMES SHALL BE DETERMINED BY THE ENGINEER. ALL REPLACED GRATES/ FRAMES SHALL BE DELIVERED TO THE CANAL DISTRICT MAINTENANCE YARD, OR AS DIRECTED WITH THE COST OF DELIVERY INCIDENTAL TO 602100/602101, REPLACING DRAINAGE INLETS GRATES/FRAMES. FINAL PAYMENT FOR REPLACED GRATES/ FRAMES SHALL NOT BE MADE UNTIL RECEIPT OF DELIVERED MATERIALS IS PRODUCED, SIGNED BY A DELDOT MAINTENANCE YARD SUPERVISOR.

17. CATCH BASINS WITH A MANHOLE SHALL BE CONVERTED TO A STANDARD CATCH BASIN AT THE DISCRETION OF THE ENGINEER. A 6" COVERSLAB WITH REBAR 6-8" ON CENTER AND MINIMUM OF 6" OF TOPSOIL ON TOP SHALL REPLACE MANHOLE. PAYMENT FOR ADDITIONAL WORK SHALL

**GENERAL CONTRACT PLAN NOTES**

BE PAID AN ADDITIONAL QUANTITY OF 0.5 THE BID AMOUNT FOR ITEM 602130 OR 602131.

18. WHEN ENCOUNTERING DELDOT STORMWATER MANHOLES WITHIN LIMITS OF PAVING, THOSE MANHOLES WILL BE ADJUSTED AND UPDATED AT THE DISCRETION OF THE ENGINEER. ITEMS 602102/602103 SHALL BE FULL COMPENSATION (FURNISH AND INSTALLING) THE NEW LIDS AND FRAMES.

19. WHEN ENCOUNTERING NEW CASTLE COUNTY SANITARY MANHOLES WITHIN THE LIMITS OF PAVING, THOSE MANHOLES WILL BE ADJUSTED AND UPDATED AT THE DISCRETION OF THE ENGINEER. THE LIDS AND FRAMES ARE PROVIDED BY NEW CASTLE COUNTY AT NO COST TO THE CONTRACTOR. OBTAINING, STORING, DELIVERING, AND PLACING THESE NEW LIDS AND FRAMES SHALL BE INCIDENTAL TO THE ADJUSTMENT ITEM 602132.

ANY ADJUSTMENTS TO THE AFOREMENTIONED MUNICIPALLY OWNED FACILITIES SHALL BE DONE IN ACCORDANCE WITH THE RESPECTIVE AGENCIES STANDARD SPECIFICATIONS, AS CONSTRUCTION WARRANTS.

- THE COUNTY REQUIRES A FULL BEARING OF BRICK BENEATH ALL ADJUSTED SANITARY MANHOLE CASTINGS.
- THE COUNTY ACCEPTS THE USE OF 1-1/2" TO 3" PRECAST P.C.C. RINGS FOR THEIR MANHOLE ADJUSTMENTS, UPON APPROVAL OF THE CONTRACTOR'S SOURCE OF MATERIALS SUBMISSION.

**SECTION 700**

20. BUTT JOINTS SHALL BE CONSTRUCTED AT ALL INTERSECTING BITUMINOUS CONCRETE ROADS AND ANY OTHER LOCATIONS AS DIRECTED BY THE ENGINEER. BUTT JOINTS AT RAILROAD CROSSINGS AND AT BRIDGE OR DRAINAGE STRUCTURES NOT TO BE RESURFACED SHALL BE AS PER THE INCLUDED PLAN DETAIL. BUTT JOINTS CUT PRIOR TO THE DAY OF PAVEMENT OVERLAY SHALL BE RAMPED WITH BITUMINOUS CONCRETE TRM, IN MILLING AREAS, INCIDENTAL TO THE ITEM 762004 BUTT JOINT. ONLY BITUMINOUS CONCRETE WILL BE ALLOWED FOR THIS PURPOSE. BUTT JOINTS IN FULL MILL AREAS SHALL BE INCIDENTAL TO THE PAVEMENT MILLING ITEM (760010). SAWCUTS FOR BUTT JOINTS SHALL BE INCIDENTAL TO THE BUTT JOINT ITEM. ALL BITUMINOUS CONCRETE TRM SHALL BE REMOVED PRIOR TO THE PAVING OPERATION.

21. THE USE OF MILLINGS AND GABC IN THE TRAVEL WAY, TEMPORARY TRAVEL WAY, HIGH VOLUME ENTRANCES AND ACCESS RAMP FOR THE PURPOSE OF PROVIDING A TEMPORARY ROADWAY SURFACE, POTHOLE REPAIR, TAPERED EDGE FOR UTILITIES, BUTT JOINTS, AND LONGITUDINAL DROP-OFFS (MILLING AND PAVING OPERATIONS) IS PROHIBITED UNLESS IT IS OTHERWISE DESIGNATED TO BE USED IN THE CONTRACT PLANS. USE COLD PATCH, BITUMINOUS CONCRETE, BITUMINOUS CONCRETE WEDGE, OR TAPER MILL, AS NOTED IN THE CONTRACT DOCUMENTS OR APPROVED BY THE ENGINEER. PAYMENT FOR COLD PATCH, BITUMINOUS

**GENERAL CONTRACT PLAN NOTES**

CONCRETE, OR BITUMINOUS CONCRETE WEDGE SHALL BE INCIDENTAL TO THE BITUMINOUS CONCRETE MILLING ITEM.

MILLINGS OR GABC SHALL BE USED AT THE FOLLOWING LOCATIONS WHERE ACCESS TO A BUSINESS RESIDENCE, OR EDGE DROP OFF NEEDS TO BE MAINTAINED UNLESS OTHERWISE NOTED IN THE PLANS OR DIRECTED BY THE ENGINEER TO USE BITUMINOUS CONCRETE OR COLD PATCH. ALL MILLING AND GABC WILL BE ROLLED AND COMPACTED TO HELP PREVENT THE MATERIAL FROM UNRAVELING.

- A. DRIVEWAYS
- B. ENTRANCES
- C. LOW VOLUME ACCESS RAMPS (IDENTIFIED IN THE CONTRACT DOCUMENTS)
- D. EDGE DROP-OFFS ADJACENT TO LIVE ROADWAY (LANE, SHOULDER, OR TURN LANE) AND THE PROPOSED ROAD CONSTRUCTION
- E. EDGE OF ROADWAY DROP-OFF

GRADING AND MAINTAINING BASE COURSE THAT IS BEING USED FOR ROADWAY WEDGE/FILLET BETWEEN TRAVEL LANES AND PAVEMENT BOX, EDGE OF TRAVEL WAY, DRIVEWAY OR ENTRANCE ACCESS SHALL BE INCIDENTAL TO ITEM NO. 801XXX - MAINTENANCE OF TRAFFIC. THE BASE COURSE MATERIAL SHALL BE PLACED AT NO GREATER THAN THE SLOPE SPECIFIED IN TABLE 6G-1 AND SHALL BE COMPACTED. EXCESS BASE COURSE MATERIAL SHALL BE PUSHED AHEAD AND USED IN THE NEXT SEGMENT AND SHALL BE INCIDENTAL TO THE PARTICULAR BASE COURSE PAY ITEM. NO SEPARATE PAYMENT SHALL BE MADE FOR MILLINGS OR GABC TEMPORARY ROADWAY MATERIAL (TRM) USED TO PROTECT EDGE DROP-OFFS, UNLESS THE MATERIAL IS EVENTUALLY UTILIZED AS PART OF A PERMANENT ROADWAY AT WHICH TIME THE MATERIAL WOULD BE PAID FOR UNDER THE RESPECTIVE CONTRACT MATERIAL ITEM. VERTICAL DIFFERENCES SHALL BE CORRECTED IN ACCORDANCE WITH TABLE 6G-1 OF THE DELAWARE MUTCD.

22. AFTER PAVEMENT MILLING, ALL TRANSVERSED VERTICAL DIFFERENCES, RAISED EDGES OF MANHOLES, DRAINAGE INLETS, WATER VALVE BOXES, ETC. SHALL BE RAMPED WITH BITUMINOUS CONCRETE TRM AT A 20:1 OR FLATTER SLOPE PRIOR TO OPENING THE ROADWAY TO TRAFFIC AND SHALL BE INCIDENTAL TO PAVEMENT MILLING. PAVEMENT MILLINGS OR COLD PATCH MATERIAL WILL NOT BE ALLOWED FOR THIS PURPOSE.

ALL ADJUSTMENTS SHALL BE MADE NOT MORE THAN SEVEN (7) CALENDAR DAYS PRIOR TO THE PLACEMENT OF THE FINAL COURSE OF BITUMINOUS CONCRETE, UNLESS DIRECTED BY THE ENGINEER. FAILURE TO COMPLY WILL RESULT IN A SUSPENSION OF ALL OTHER CONTRACT WORK WITH TIME CHARGES CONTINUING TO BE ASSESSED.

**GENERAL CONTRACT PLAN NOTES**

ALL BITUMINOUS CONCRETE TRM SHALL BE REMOVED PRIOR TO THE PAVING OPERATIONS. IF THE CONTRACTOR ELECTS TO ADJUST MANHOLES, DRAINAGE INLETS AND WATER VALVES AFTER THE FINAL COURSE OF PAVING, THIS WORK MUST BE COMPLETED WITHIN SEVEN (7) CALENDAR DAYS OF THE FINAL COURSE OF BITUMINOUS CONCRETE. FAILURE TO COMPLY WILL RESULT IN A SUSPENSION OF ALL OTHER CONTRACT WORK WITH TIME CHARGES CONTINUING TO BE ASSESSED.

23. THE CONTRACTOR SHALL TAKE CARE IN REMOVING PAVEMENT AROUND UTILITIES, BUTT JOINTS, CURBS, ETC. SO THAT EXISTING PAVEMENT BEYOND THE SPECIFIED DEPTHS IS NOT DAMAGED. ANY DAMAGE CAUSED BY THE CONTRACTOR'S OPERATIONS MAY RESULT IN PLACING LEVELING COURSES AT THE CONTRACTOR'S EXPENSE. THE REMOVAL AND CLEAN UP OF THE HOT MIX RESIDUE WEDGE REMAINING AFTER MILLING OPERATIONS SHALL BE INCIDENTAL TO THE MILLING ITEM. THE REMOVAL OF EXISTING RAISED PAVEMENT MARKERS (RPM'S) SHALL BE INCIDENTAL TO THE APPLICABLE MILLING AND/OR RECLAMATION ITEMS.

24. TAPER MILLING IS INTENDED FOR MILLING IN THE AREA OF FIXED STRUCTURES (I.E. CURBS, MANHOLES, ETC.) THE MILLED DEPTH AT THE STRUCTURE SHALL BE THE DEPTH OF THE PROPOSED OVERLAY AND 0" AT A DISTANCE OF +/- 6 ½ FEET FROM THE STRUCTURE. THE COMPUTED DEPTH FOR PAYMENT PURPOSES IS THE AVERAGE OF THE TWO DEPTHS.

25. ON THIS CONTRACT FULL MILL AREAS WILL UTILIZE ITEM 760010 PAVEMENT MILLING, BITUMINUOUS CONCRETE PAVEMENT (SY-IN). UNLESS OTHERWISE NOTED, ALL MILLING LOCATIONS ARE EXPECTED TO BE MILLED AT A 2" DEPTH. FOR AVERAGE MILLING DEPTHS OF 0.5" TO AN AVERAGE MILLING DEPTH OF 2.25", THE FULL MILL AREAS WILL BE PAID AT AN AVERAGE 2".

26. MILLING OF BITUMINOUS PAVEMENT IN PREPARTION FOR OVERLAY IS TO INCLUDE MILLING EXISTING CONCRETE PATCHES AND/OR COMPOSITE PAVING AND SHOULD BE CONSIDERED INCIDENTAL TO ITEM 760010, PAVEMENT MILLING, BITUMINOUS CONCRETE PAVEMENT.

27. ALL MILLED MATERIAL SHALL REMAIN THE PROPERTY OF THE CONTRACTOR UNLESS OTHERWISE STATED.

28. AT LOCATIONS THAT HAVE PCC REPLACEMENT, PAVING MUST BE COMPLETED WITHIN 90 CALENDAR DAYS FROM THE START OF THE PCC REPLACEMENT. BETWEEN OCTOBER 15TH AND NOVEMBER 30<sup>TH</sup>, PAVING MUST BE COMPLETED WITHIN 30 CALENDAR DAYS FROM THE START OF THE PCC REPLACEMENT. FAILURE TO COMPLY WILL RESULT IN A SUSPENSION OF ALL OTHER CONTRACT WORK WITH TIME CHARGES CONTINUING TO BE ASSESSED.

---

DEPARTMENT OF TRANSPORTATION

---

CONTRACT NUMBER- T202503120 CANAL  
COMMUNITY TRANSPORTATION FUND, WILMINGTON, 2025

(CAD) PAGE 23 OF 84

---

GENERAL CONTRACT PLAN NOTES

29. UPRIGHT PCC CURB UTILIZED FOR GRADE RETENTION 8" OR HIGHER WILL BE PAID AS 701013, TYPE 1-8 CURB.

30. EXCAVATION UP TO 2' IN FRONT OF CURB, ADA FACILITIES, AND DRAINAGE INLETS WILL BE INCIDENTAL TO THE CORRESPONDING ITEMS (701XXX, 705XXX, AND 602XXX). HOT MIX PLACED IN FRONT OF CURB WILL BE PAID UNDER ITEM 401XXX. USE OF CONCRETE AS FILL IN FRONT OF CURB WILL NOT BE ACCEPTED UNLESS DIRECTED BY THE ENGINEER. AT EACH LOCATION, BACKFILLING SHALL BE PERFORMED IMMEDIATELY UPON REMOVAL OF FORMS FOR CURB OR SIDEWALK. TOPSOIL, SEEDING, SEALING OF VALLEY GUTTERS, REMOVING OF FORMS, AND PARGING OF CATCH BASINS, SHALL BE COMPLETED WITHIN SEVEN (7) CALENDAR DAYS OF COMPLETION OF THE ITEM OF WORK. ITEM 908001, TOPSOIL, SHALL BE USED AS BACKFILL MATERIAL BEHIND CURB AND AROUND SIDEWALK OR/AS DIRECTED BY THE ENGINEER. TOPSOIL SHALL BE SCREENED/SIFTED SO AS NO MATERIAL GREATER THAN .5" SHOULD BE PRESENT IN MATERIAL USED FOR BACKFILL. EXCAVATED MATERIAL, NOT NEEDED ON THE PROJECT, SHALL BE REMOVED FROM THE CONTRACT AT THE CONTRACTORS EXPENSE. FAILURE TO COMPLY WILL RESULT IN A SUSPENSION OF ALL OTHER CONTRACT WORK WITH THE CHARGES CONTINUING TO BE ASSESSED.

31. AS DIRECTED BY THE ENGINEER, THE CONTRACTOR SHALL PARTIALLY SAW AND FILL EXISTING CRACKED CURB AND/OR SIDEWALK WITH AN APPROVED SEALER. THIS WORK WILL BE INCIDENTAL TO ITEM 762001 SAWCUT - CONCRETE FULL DEPTH.

32. PERTAINING TO PCC CURB REMOVAL & PATCHING, SAWCUTTING IS TO BE PERFORMED PRIOR TO THE REMOVAL OF BITUMINOUS CONCRETE UNLESS APPROVAL IS GIVEN BY THE ENGINEERS REPRESENTATIVE.

33. BEFORE THE START OF A DAY'S PAVEMENT MILLING OR PAVING OPERATIONS AND WHERE THERE IS EXISTING STRIPING, THE CONTRACTOR SHALL BE REQUIRED TO PROVIDE PROOF THAT SUFFICIENT APPROVED STRIPING MATERIALS ARE ON HAND TO ENSURE STRIPING IS COMPLETE BEFORE TRAFFIC IS RETURNED TO THE ROADWAY.

34. LANE CLOSURES ON 3-DIGIT MAINTENANCE ROADS ARE PERMITTED ONLY BETWEEN THE HOURS OF 9:00 AM AND 3:00 PM, MONDAY - FRIDAY. ANY VARIANCE SHALL REQUIRE DISTRICT SAFETY OFFICERS APPROVAL.

35. ITEM 710370 STEEL CASING PIPE-4" IS DESIGNATED FOR NOW-DEFUNCT ITEM 718000 ROOF DRAIN. WHEN REPLACING OR EXTENDING ROOF DRAINS, SUMP PUMP DRAINS, ETC. FROM RIGHT-OF-WAY TO CURBLINE, ITEM 710370 WILL BE UTILIZED REGARDLESS OF PIPE MATERIAL OR SIZE.

36. GAS VALVE, MONUMENT BOX, AND LAMP HOLE ADJUSTMENTS WILL BE PAID AS 710002, WATER VALVE ADJUSTMENTS.

---

**DEPARTMENT OF TRANSPORTATION**

---

**CONTRACT NUMBER- T202503120 CANAL  
COMMUNITY TRANSPORTATION FUND, WILMINGTON, 2025**

**(CAD) PAGE 24 OF 84**

---

**GENERAL CONTRACT PLAN NOTES**

37. REMOVAL OF ANY UNSUITABLE MATERIALS INCLUDING ROOTS AND VEGETATIVE MATTER DISCOVERED WITHIN OR DIRECTLY BELOW THE TEMPLATE OF PCC / GRANITE CURB, PEDESTRIAN FACILITIES, AND/OR PCC / BRICK SIDEWALKS SHALL BE INCIDENTAL TO THE CORRESPONDING ITEM.

38. TRASH, RUBBISH, DEBRIS, OR BRUSH THAT HAMPERS REPAIR/MAINTENANCE WORK IN THIS CONTRACT (AS DETERMINED BY THE ENGINEER), SHALL BE REMOVED WITHIN THE PROJECT LIMITS AND SHALL BE INCIDENTAL TO PAY ITEM 763000 (INITIAL EXPENSE/DEMobilIZATION).

39. CLEARING AND GRUBBING INCLUDES OBTAINING WIDTH AND HEIGHT REQUIREMENTS FOR PAR AND CLEARING OF SIGHT DISTANCE (INCLUDING EXISTING FACILITIES AND SIGNS). CLEARING AND GRUBBING OF TREES, SHRUBS AND OTHER VEGETATION LESS THAN 6" IN DIAMETER SHALL BE INCIDENTAL TO ITEM 763000 (INITIAL EXPENSE/DEMobilIZATION).

40. GRASS AND SOIL AREAS WITHIN THE STATE RIGHT-OF-WAY AND ADJACENT PRIVATE PROPERTY THAT HAS BEEN DAMAGED DURING CONTRACT OPERATIONS SHALL BE RESTORED WITH TOPSOIL, SEED AND MULCH AT THE CONTRACTOR'S EXPENSE. WORK SHALL BE EXECUTED IN ACCORDANCE WITH THE REQUIREMENTS FOR ITEM 908001 (TOPSOIL), ITEM 908016 (PERMANENT GRASS SEEDING SUBDIVISION), AND ITEM 908020 (EROSION CONTROL BLANKET MULCH). REPAIRS MUST BE COMPLETED WITHIN SEVEN (7) CALENDAR DAYS OF NOTIFICATION. FAILURE TO COMPLY WILL RESULT IN A SUSPENSION OF ALL OTHER CONTRACT WORK WITH TIME CHARGES CONTINUING TO BE ASSESSED.

**SECTION 800**

41. MESSAGE BOARDS SHALL BE PLACED 10 DAYS IN ADVANCE OF THE WORK AND SHALL REMAIN IN PLACE FOR 5 DAYS AFTER THE START OF WORK. LOCATIONS OF MESSAGE BOARDS AND MESSAGES DISPLAYED SHALL BE REVIEWED AND APPROVED BY THE DISTRICT SAFETY OFFICER.

42. AT EACH LOCATION, THE CONTRACTOR SHALL NOTE ALL EXISTING PAVEMENT MARKINGS AND SUBMIT A DRAWING WHICH DEPICTS THE STRIPING PATTERN TO THE DEPARTMENT PRIOR TO THE START OF ANY WORK AT THE LOCATION.

AT THE END OF EACH DAY'S OPERATION AND BEFORE TRAFFIC IS RETURNED TO UNRESTRICTED ROADWAY USE, TEMPORARY MARKINGS SHALL BE UTILIZED AT LOCATIONS THAT REQUIRE PERMANENT MARKING. TEMPORARY PAVEMENT STRIPING MUST MATCH PERMANENT PAVEMENT STRIPING IN ALL REGARDS.

**GENERAL CONTRACT PLAN NOTES**

TEMPORARY PAVEMENT MARKINGS SHALL BE PAID AT THE APPLICABLE CONTRACT UNIT PRICE. THE CONTRACTOR IS RESPONSIBLE FOR MAINTAINING THE TEMPORARY MARKINGS IN GOOD CONDITION SUCH THAT THE PAVEMENT IS PROPERLY DELINEATED AT ALL TIMES. ANY REFRESHING OF THE TEMPORARY MARKINGS WILL BE AT THE CONTRACTOR'S EXPENSE.

FINAL PAVEMENT MARKINGS SHALL CONFORM TO ALL EXISTING PATTERNS AND SHALL BE PLACED WITHIN FIVE (5) CALENDER DAYS (MAXIMUM) AFTER PLACEMENT OF THE FINAL COURSE OF BITUMINOUS CONCRETE. IF THE CONTRACTOR FAILS TO DOCUMENT THE EXISTING PAVEMENT MARKINGS IN AN ACCEPTABLE MANNER, HE SHALL BE REQUIRED TO PROVIDE AT HIS OWN EXPENSE, A NEW PAVEMENT MARKING PLAN SIGNED AND SEALED BY A PROFESSIONAL ENGINEER REGISTERED IN THE STATE OF DELAWARE.

ANY ERRONEOUS MARKING WILL NOT BE PAID FOR AND SHALL BE CORRECTED IMMEDIATELY AT THE CONTRACTOR'S EXPENSE. ERRONEOUS MARKINGS OR SHADOWS THAT EXCEED ONE (1) INCH IN WIDTH SHALL BE REMOVED BY EITHER SAND OR WATER BLASTING. NO OTHER REMOVAL METHODS WILL BE ALLOWED. A FLAT BLACK PAINT OR DRIVEWAY SEALER SHALL BE APPLIED IN THE AREA OF THE REMOVED MARKING TO MASK THE REPAIR. ANY DAMAGE TO THE PAVEMENT CAUSED BY REMOVAL OF ERRONEOUS MARKINGS SHALL BE REPAIRED / REPLACED TO THE SATISFACTION OF THE ENGINEER. FAILURE TO COMPLY WILL RESULT IN SUSPENSION OF ALL OTHER CONTRACT WORK WITH TIME CHARGES CONTINUING TO BE ASSESSED.

43. THE CONTRACTOR, WITH THE ENGINEER, SHALL INVENTORY ALL SIGNS ON ALL ROADS SUBJECT TO IMPROVEMENTS. NECESSARY SIGNS SHALL BE MAINTAINED IN OPERATION DURING CONSTRUCTION AND ANY OTHER SIGNS SHALL BE PROPERLY STORED WITH THE CONTRACTOR, WHO SHALL BE RESPONSIBLE FOR LOSS OR DAMAGE. IMMEDIATELY PRIOR TO FINAL INSPECTION, THE CONTRACTOR AND ENGINEER SHALL AGAIN INVENTORY THE TRAFFIC SIGNS AND ACCOUNT FOR ANY LOST OR DAMAGED SIGNS. LOST OR DAMAGED SIGNS, AT THE DISCRETION OF THE ENGINEER SHALL BE REPLACED IN KIND AT THE CONTRACTOR'S EXPENSE.

44. REGULATORY SIGNS REMOVED MUST BE REINSTALLED THE SAME DAY. IN ABSENCE OF A SIGN SCHEDULE, INSTALLATION OR REMOVAL OF TRAFFIC SIGN(S) AND SIGN POST(S) WILL BE PAID AS 819018. THIS ITEM WILL BE PAID ONE TIME PER POST AFTER FINAL INSTALLATION.

45. A FORMAL DETOUR WILL NOT BE NECESSARY ON THIS CONTRACT. THE CONTRACTOR MUST MAINTAIN LOCAL TRAFFIC WITHIN THE PROJECT LIMITS UTILIZING FLAGGERS. MAINTENANCE OF TRAFFIC DURING LANE CLOSURES AND/OR LANE SHIFTS SHALL CONFORM TO TYPICAL APPLICATIONS OF THE DELAWARE MUTCD. ANY VARIANCE SHALL REQUIRE DISTRICT SAFETY

**GENERAL CONTRACT PLAN NOTES**

OFFICERS APPROVAL.

46. BEFORE WORK IS DONE AT ANY LOCATION, THE APPROPRIATE DISTRICT SAFETY OFFICER MUST APPROVE THE MOT FOR THAT LOCATION TWO WEEKS IN ADVANCE. ANY ANTICIPATED IMPACT TO TRAFFIC SIGNALS MUST BE REVIEWED BY THE DELDOT TRAFFIC SECTION PRIOR TO CONSTRUCTION. THEY CAN BE CONTACTED AT 302-659-4061.

47. THE CONTRACTOR SHALL SUBMIT A TRAFFIC CONTROL PLAN, INCLUDING PEDESTRIAN AND BICYCLE FACILITIES, FOR ALL DEVICES THAT WILL BE UTILIZED BEFORE THE START OF THE PRE-CONSTRUCTION MEETING. ALL TRAFFIC CONTROL DEVICES SHALL BE IN NEW OR REFURBISHED CONDITION, SHALL BE IN COMPLIANCE WITH THE MANUAL FOR ASSESSING SAFETY HARDWARE (MASH) CERTIFICATIONS, AND ON DELDOTS APPROVED PRODUCTS LIST (APL). THE DEVICES SHALL BE APPROVED BY THE SAFETY SECTION PRIOR TO USE AND SHALL BE MAINTAINED IN GOOD CONDITION FOR THE DURATION OF THE CONTRACT.

48. ALL WORK SHALL BE PERFORMED IN A MANNER THAT WILL REASONABLY PROVIDE THE LEAST PRACTICABLE OBSTRUCTION TO ALL ROAD USERS, INCLUDING VEHICULAR, PEDESTRIAN AND BICYCLE TRAFFIC, AND SHALL CONFORM TO THE REQUIREMENTS OF THE 2011 DELAWARE MANUAL ON UNIFORM TRAFFIC CONTROL DEVICES, PART 6, INCLUDING ALL REVISIONS UP TO THE DATE OF ADVERTISEMENT FOR BIDS.

49. CURB RAMP AND/OR SIDEWALK CONSTRUCTION (NOT INCLUDING MEDIAN ISLANDS) SHALL BE COMPLETED DURING A SINGLE OPERATION. THE RAMP/SIDEWALK SHALL BE REMOVED AND PLACED BACK THE SAME NIGHT/DAY AND OPEN TO PEDESTRIAN TRAFFIC THE FOLLOWING DAY. THE USE OF A MONOLITHIC POUR SHALL BE PERMITTED WITH A BOND BREAKER TO BE PLACED AT THE BACK OF THE CURB AND EDGE OF SIDEWALK. IF THE CURB RAMP/SIDEWALK CANNOT BE COMPLETED IN A SINGLE OPERATION THE EXCAVATED AREA MUST BE TEMPORARILY BACKFILLED TO GRADE WITH COMPACTED MILLING MATERIAL ONLY. THIS TEMPORARY MATERIAL WILL BE INCIDENTAL TO THE CURB RAMP ITEM. THE DRESSING UP OF THE AREA BEING PAID AS A CURB RAMP WITH TOPSOIL AND SEED WILL BE PAID AT CONTRACT UNIT PRICES. THE CONTRACTOR SHALL MAINTAIN ACCESS TO AND ALONG PEDESTRIAN FACILITIES AT ALL TIMES DURING CONSTRUCTION. EARTH, STONE AND GRAVEL SURFACES ARE NOT ACCEPTABLE FOR PROVIDING PEDESTRIAN ACCESS. IF CURB RAMP CANNOT BE COMPLETED IN A SINGLE OPERATION AND PEDESTRIAN ROUTES ARE CLOSED OR BLOCKED, ALTERNATE PEDESTRIAN ACCESS SHALL BE PROVIDED USING TA-28 AND/OR TA-29 OF THE 2011 DELAWARE MANUAL ON UNIFORM TRAFFIC CONTROL DEVICES OR TO THE SATISFACTION OF THE ENGINEER. PEDESTRIAN DETOUR ROUTES OR ALTERNATE PEDESTRIAN FACILITIES SHALL CONSIST OF ADA COMPLIANT FACILITIES TO THE LEVEL OF WHICH EXISTS ON THE PEDESTRIAN ROUTE. THE COST FOR ANY PROVISIONS SHALL BE INCIDENTAL TO ITEM 801500 - MAINTENANCE OF TRAFFIC - ALL INCLUSIVE.

PEDESTRIAN MAINTENANCE OF TRAFFIC: THIS WORK SHALL CONSIST OF PROVIDING AND MAINTAINING AN ACCESSIBLE PEDESTRIAN ROUTE THROUGHOUT THE PROJECT'S LIMITS IN

**GENERAL CONTRACT PLAN NOTES**

ACCORDANCE WITH THE AMERICANS WITH DISABILITIES ACT OF 1990 (ADA) TITLE II, PARAGRAPH 35.130.

THE CONTRACTOR SHALL BE REQUIRED TO REVIEW EACH CURB RAMP LOCATION AND SUBMIT THE APPROPRIATE MAINTENANCE OF TRAFFIC DETAIL AND DEVICES TO THE ENGINEER FOR EACH LOCATION AT LEAST 2-WEEKS BEFORE CONSTRUCTION FOR REVIEW, COMMENT, AND APPROVAL BY THE DISTRICT SAFETY OFFICER.

THE FOLLOWING CONSIDERATIONS SHALL BE TAKEN INTO ACCOUNT WHEN ADDRESSING ACCESSIBLE PEDESTRIAN MAINTENANCE OF TRAFFIC:

- ALL PEDESTRIANS, INCLUDING PERSONS WITH DISABILITIES, SHALL BE PROVIDED WITH A REASONABLY SAFE, CONVENIENT AND ACCESSIBLE PATH THAT REPLICATES AS MUCH AS PRACTICABLE THE EXISTING PEDESTRIAN FACILITIES.
- MAINTAIN ACCESS TO ALL BUSINESS AND RESIDENTS AT ALL TIMES.
- PROVIDE PEDESTRIAN ACCESS THRU OR AROUND THE WORK ZONE. IF A DETOUR IS CHOSEN THE CONTRACTOR MUST SUBMIT THE DETOUR ROUTE TO THE ENGINEER FOR REVIEW AND APPROVAL. THE DETOUR ROUTE MUST MEET OR EXCEED THE CURRENT CONDITIONS.
- WORK SHOULD BE PHASED SO THAT ALL AREAS OF AN INTERSECTION/SIDEWALK PATH ARE NOT UNDER CONSTRUCTION AT THE SAME TIME UNLESS A CLEAR PATH IS PROVIDED AND IDENTIFIED.
- TRAFFIC CONTROL DEVICES AND OTHER CONSTRUCTION MATERIALS AND FEATURES SHALL NOT INTRUDE INTO THE USABLE WIDTH OF THE SIDEWALK, TEMPORARY PATHWAY OR OTHER PEDESTRIAN FACILITY.
- SIGNS AND OTHER DEVICES MOUNTED LOWER THAN 7 FT ABOVE THE TEMPORARY PEDESTRIAN PATHWAY SHALL NOT PROJECT MORE THAN 4 IN. INTO ACCESSIBLE PEDESTRIAN ROUTE.
- A SMOOTH, CONTINUOUS HARD SURFACE SHALL BE PROVIDED THROUGHOUT THE ENTIRE LENGTH AND WIDTH OF THE PEDESTRIAN ROUTE THROUGHOUT CONSTRUCTION. THERE SHALL BE NO CURBS OR VERTICAL ELEVATION CHANGES GREATER THAN ¼ IN. IN GRADE OR TERRAIN THAT COULD CAUSE TRIPPING OR BE A BARRIER TO WHEELCHAIR USE.

**SECTION 900**

50. EROSION CONTROL MULCH BLANKET SHALL BE USED IN ALL DISTURBED AREAS UNLESS DIRECTED OTHERWISE BY THE ENGINEER.

**ADDITIONAL PROJECT NOTES**

**GENERAL CONTRACT PLAN NOTES**

51. UNDERGROUND UTILITIES MAY BE PRESENT AT ALL LOCATIONS. THEREFORE, ALL STANDARD PRACTICES AND PROCEDURES REGARDING UTILITIES SHALL BE FOLLOWED. THE CONTRACTOR SHALL CONTACT MISS UTILITY OF DELAWARE PRIOR TO STARTING WORK. THE CONTRACTOR IS RESPONSIBLE FOR THE SUPPORT AND PROTECTION OF ALL UTILITIES WHEN EXCAVATING WHICH SHALL BE INCIDENTAL TO THE RESPECTIVE EXCAVATION ITEM(S). THE CONTRACTOR IS RESPONSIBLE FOR ENSURING PROPER CLEARANCES, INCLUDING SAFETY CLEARANCES, FROM OVERHEAD UTILITIES FOR CONSTRUCTION EQUIPMENT. THE CONTRACTOR IS ADVISED TO CHECK THE SITE FOR ACCESS PURPOSES FOR THEIR EQUIPMENT AND MAKE ARRANGEMENTS DIRECTLY WITH THE UTILITY COMPANIES FOR FIELD ADJUSTMENTS FOR ADEQUATE CLEARANCES, IF NECESSARY.

52. NO UTILITY RELOCATION INVOLVEMENT IS ANTICIPATED. SHOULD ANY CONFLICTS BE ENCOUNTERED DURING CONSTRUCTION REQUIRING ADJUSTMENT AND/OR RELOCATION OF THE AGENCIES' EXISTING FACILITIES, THE NECESSARY RELOCATION WORK SHALL BE ACCOMPLISHED BY THE RESPECTIVE AGENCIES' FORCES, AS DIRECTED BY THE DISTRICT ENGINEER. ANY ADJUSTMENTS AND/OR RELOCATIONS OF MUNICIPALLY OWNED FACILITIES SHALL BE DONE BY THE STATE'S CONTRACTOR IN ACCORDANCE WITH THE RESPECTIVE AGENCIES' STANDARD SPECIFICATIONS AS DIRECTED BY THE DISTRICT ENGINEER.

53. NO ENVIRONMENTAL PERMITS ARE REQUIRED FOR THIS WORK PROVIDED NO JURISDICTIONAL WETLANDS OR WATERS ARE IMPACTED. IF THERE IS ANY QUESTION AS TO WHETHER OR NOT A WATER OR WETLAND IS JURISDICTIONAL, CONTACT THE DEL DOT ENVIRONMENTAL SECTION AT 302-760-2264.

54. IT IS ANTICIPATED THAT ALL WORK WILL OCCUR WITHIN DELDOT'S EXISTING RIGHT OF WAY OR EASEMENT AREAS. SHOULD THE NEED OCCUR TO TRESPASS ONTO PRIVATE PROPERTY; IT WILL BE THE RESPONSIBILITY OF THE PROJECT MANAGER TO SECURE SUCH TRESPASS NEEDS.

55. NO WORK NEAR OR WITHIN RAILROAD RIGHT-OF-WAY IS ANTICIPATED. IF ANY RAILROAD PROPERTY OR FACILITIES ARE NEAR OR WITHIN THE PROPOSED LIMITS OF WORK OR IF THE PROPOSED WORK ENCROACHES UPON THE RAILROAD'S RIGHT-OF-WAY, THE CONTRACTOR SHALL BE RESPONSIBLE FOR OBTAINING THE REQUIRED CLEARANCES AND INSURANCES FOR EACH INVOLVED RAILROAD IN ACCORDANCE WITH THE APPROPRIATE DELDOT MAINTENANCE OF RAILROAD TRAFFIC ITEM. DELDOT'S RAILROAD SECTION MANAGER MUST BE CONTACTED AT (302) 760-2183 TO COORDINATE THE EXECUTION OF THE APPROPRIATE AGREEMENTS AND AUTHORIZATIONS REQUIRED FROM ANY RAILROAD COMPANY INVOLVED, INCLUDING COORDINATION FOR RAILROAD FLAGGING, IF NECESSARY.

---

**DEPARTMENT OF TRANSPORTATION**

---

**CONTRACT NUMBER- T202503120 CANAL  
COMMUNITY TRANSPORTATION FUND, WILMINGTON, 2025**

**(CAD) PAGE 29 OF 84**

---

**GENERAL CONTRACT PLAN NOTES**

56. THE PROJECT MANAGER SHALL BE RESPONSIBLE FOR COORDINATING WITH THE TRAFFIC SECTION RELATING TO ANY IMPACTS TO TRAFFIC SECTION FACILITIES (INCLUDING BUT NOT LIMITED TO TRAFFIC LOOPS, JUNCTION WELLS ETC.) AT LEAST 4 WEEKS IN ADVANCE OF THE START OF THE ACTIVITY. PRIOR TO INITIATING ANY WORK ON THIS CONTRACT (OR SITES), THE PROJECT MANAGER SHALL BE RESPONSIBLE FOR PREPARING AND SUBMITTING FOR APPROVAL OF THE SAFETY SECTION, A MAINTENANCE OF TRAFFIC PLAN. SUFFICIENT TIME SHALL BE PROVIDED FOR THE REVIEW AND APPROVAL OF THE PLAN. THE MAINTENANCE OF TRAFFIC PLAN SHALL INCLUDE PROPOSED TIME RESTRICTIONS ON THE CLOSURE OF TRAVEL LANES SUBJECT TO THE APPROVAL OF THE SAFETY SECTION. TRAFFIC LOOPS MUST BE PUT BACK WITHIN 7 DAYS OF PAVING, FAILURE TO COMPLY WILL RESULT IN A SUSPENSION OF ALL OTHER CONTRACT WORK WITH TIME CHARGES CONTINUING TO BE ASSESSED.

57. THE DEPARTMENT RESERVES THE RIGHT TO REQUEST AN EXTENSION OF THIS CONTRACT, WITH THE AGREEMENT OF THE CONTRACTOR, AT THE CURRENT CONTRACT PRICES.

Jan 2025

**CITY OF WILMINGTON COMMENTS**

58. THE CITY REQUIRES THAT THE CONTRACTORS NAME BE STAMPED INTO THE SIDEWALK. THE CITY CODE OF ORDINANCES, PART II, CHAPTER 42, ARTICLE I, DIVISION I SEC. 42-110 STATES: "CONTRACTOR'S NAME TO BE STAMPED OR INLAID INTO SIDEWALK".

A. THE CONTRACTOR SHALL MARK HIS NAME IN THE SIDEWALK, EITHER BY STAMPING OR BY INLAYING AN IMPROVED METAL PLATE. THE STAMPED LETTERS SHALL BE ONE INCH HIGH AND ONE-QUARTER INCH DEEP. IF A METAL PLATE IS USED, THE TOP OF THE PLATE SHALL BE FLUSH WITH THE TOP OF THE SIDEWALK.

B. THE CONTRACTOR'S NAME SHALL BE PLACED AT EACH END OF THE FINISHED SIDEWALK UP TO 100 FEET IN LENGTH. BEYOND THE 100 FEET LENGTH, THE CONTRACTOR'S NAME SHALL BE PLACED AT THE ENDS OF THE FINISHED SIDEWALK AND MIDDISTANT BETWEEN THE ENDS."

59. THE CITY CODE REQUIRES EXPANSION JOINTS BETWEEN CONCRETE CURB AND CONCRETE SIDEWALK.

60. THE CITY REQUIRES THAT GRANITE CURB NOT BE REPLACED WITH ANY OTHER KIND OF CURB EXCEPT AT ADA RAMPS. THE CITY CODE OF ORDINANCES, PART II, CHAPTER 42, ARTICLE I, DIVISION I SEC. 42-49 STATES "EXISTING GRANITE CURBS MAY NOT BE REPLACED WITH ANY OTHER TYPE OF CURBING MATERIALS, EXCEPT THAT GRANITE CURBS MAY BE REPLACED BY CONCRETE CURBS WHERE NECESSARY TO THE CONSTRUCTION OF A RAMP FOR A WHEELCHAIR ACCESS TO AND FROM THE ADJOINING STREET. GRANITE CURBING, WHEN AUTHORIZED TO BE REMOVED PURSUANT TO THIS SECTION, SHALL BE DELIVERED TO AND STORED ON CITY PROPERTY AT A LOCATION OR LOCATIONS DESIGNATED BY THE DEPARTMENT OF PUBLIC WORKS FOR THE SAME, AND SHALL THERE BE MADE

---

**DEPARTMENT OF TRANSPORTATION**

---

**CONTRACT NUMBER- T202503120 CANAL  
COMMUNITY TRANSPORTATION FUND, WILMINGTON, 2025**

**(CAD) PAGE 30 OF 84**

---

**GENERAL CONTRACT PLAN NOTES**

AVAILABLE WITHOUT CHARGE TO ANY PERSON DESIRING TO REPAIR OR CONSTRUCT A GRANITE CURB IN THE CITY. IF THE SUPPLY OF GRANITE CURBING SO STORED SHOULD AT ANY TIME SUBSTANTIALLY EXCEED THE POTENTIAL NEED FOR GRANITE CURBING FOR SUCH CONSTRUCTION OR REPAIRS, THE DEPARTMENT OF PUBLIC WORKS SHALL BE AUTHORIZED TO SELL, UTILIZE, OR OTHERWISE DISPOSE OF SUCH EXCESS SUPPLY OF GRANITE CURBS.”

61. ALL TREE WORK INCLUDING BUT NOT LIMITED TO REMOVAL, REPLACEMENT, TRIMMING OR ROOT TRIMMING IS TO BE APPROVED BY THE CITY FORESTER/ARBORIST.

62. OVER NIGHT STORAGE OF CONTRACTORS EQUIPMENT AND MATERIALS IS NOT PERMITTED ON CITY STREETS.

63. CONTRACTORS PERFORMING WORK WITHIN THE CITY OF WILMINGTON ARE REQUIRED TO HOLD A CITY LICENSE.

64. TRAFFIC OFFICERS MAY BE USED AT THE DISCRETION OF THE PROJECT MANAGER WHERE ISSUES ARE ANTICIPATED WITHIN THE LIMITS OF THE PROJECT.

65. ALL CONSTRUCTION DEBRIS (MILLINGS, HOT MIX, CONCRETE STONES ETC.) THAT ENTER INSIDE OF A SEWER APPURTENANCE (CATCH BASINS, MANHOLES, LAMP HOLES, ETC.) DURING THE PAVING/MILLING/CASTING ADJUSTMENT PROCESS SHALL BE REMOVED THE SAME DAY.

66. CITY OF WILMINGTON SEWER MANHOLES SHALL BE ADJUSTED AS FOLLOWS (IF ADJUSTMENT IS NECESSARY): NO MORE THAN ONE CONCRETE RING (IF NECESSARY) ADD RED BRICKS. CONCRETE BRICKS ARE PROHIBITED.

67. ATTACHED IS THE DETAILS FOR THE CITY OF WILMINGTON – DEPARTMENT OF PUBLIC WORKS MANHOLE FRAME AND COVER (OR SIMILAR IN DESIGN AND MARKINGS). THE CITY OF WILMINGTON WILL SUPPLY THE MANHOLE FRAME AND COVER IF SUPPLY IS AVAILABLE. CONTRACTORS WILL HAVE TO ARRANGE A TIME WITH THE DEPARTMENT OF PUBLIC WORKS TO PICK UP FRAMES AND COVER. A MINIMUM OF 24 HOURS’ NOTICE IS NEEDED.

68. EXISTING U-CHANNEL SIGNPOSTS LOCATED IN REPAIR AREAS SHALL BE REMOVED. CONTRACTOR WILL SUPPLY AND INSTALL NEW GALVANIZED TELESCOPING STEEL SIGNPOST. REMOVAL OF EXISTING SIGNPOST WILL BE INCIDENTAL TO ITEM #819023 - GALVANIZED TELESCOPING STEEL SIGNPOSTS, 15’x2”, COMPLETE W/BASEPOSTS AND HARDWARE. REMOVING EXISTING SIGNS FROM EXISTING SIGNPOST AND MOUNTING TO NEW POST WILL BE INCIDENTAL TO ITEM #819023.

69. REMOVAL OF EXISTING BRICK IS INCIDENTAL TO ITEM #705504 - BRICK AND/OR BLOCK. SIDEWALK. THE 4” CLASS B CONCRETE BASE MAY OMITED AT ENGINEERS DISCRETION.

70. REMOVAL OF EXISTIING BRICK IS INCIDENTAL TO ITEM #705505 – RESET STONE/BRICK SIDEWALK.

---

**DEPARTMENT OF TRANSPORTATION**

---

**CONTRACT NUMBER- T202503120 CANAL  
COMMUNITY TRANSPORTATION FUND, WILMINGTON, 2025**

**(CAD) PAGE 31 OF 84**

---

**GENERAL CONTRACT PLAN NOTES**

71. STUMP/ROOT REMOVAL SHALL FOLLOW SPECIAL PROVISION ITEM #211510. CONTRACTOR WILL COORDINATE WITH APPROPRIATE UTILITY PROVIDER FOR PROPER PROCEDURE OF STUMP/ROOT REMOVAL WITH UTILITIES IN THE VICINITY OF WORK LIMITS. ANY TEST HOLES, ADDITIONAL TIME OR REMOBILIZATION REQUIRED TO COMPLETE STUMP/ROOT REMOVAL WILL BE INCIDENTAL TO ITEM #211510.

DELAWARE DEPARTMENT OF TRANSPORTATION

CONTRACT NUMBER- T202503120

(CAD) PAGE 32 OF 84

CANAL

Contract is for various locations throughout New Castle County.

DETAILS SHEET

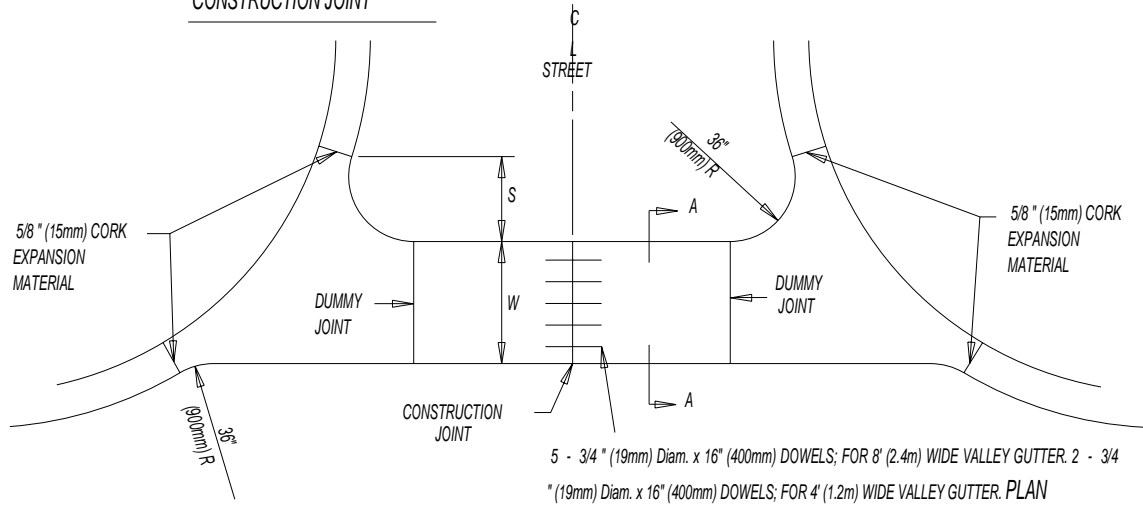
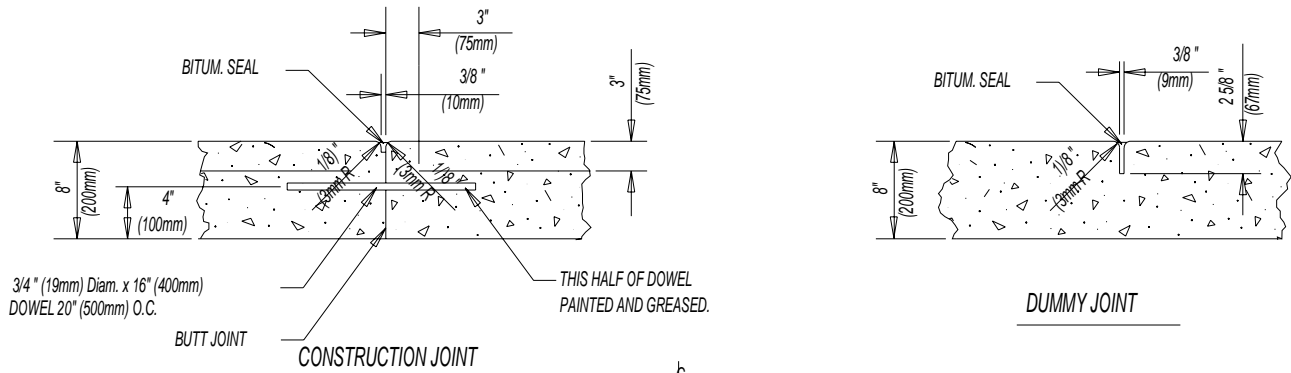

5 - 3/4" (19mm) Diam. x 16" (400mm) DOWELS; FOR 8' (2.4m) WIDE VALLEY GUTTER. 2 - 3/4" (19mm) Diam. x 16" (400mm) DOWELS; FOR 4' (1.2m) WIDE VALLEY GUTTER. PLAN

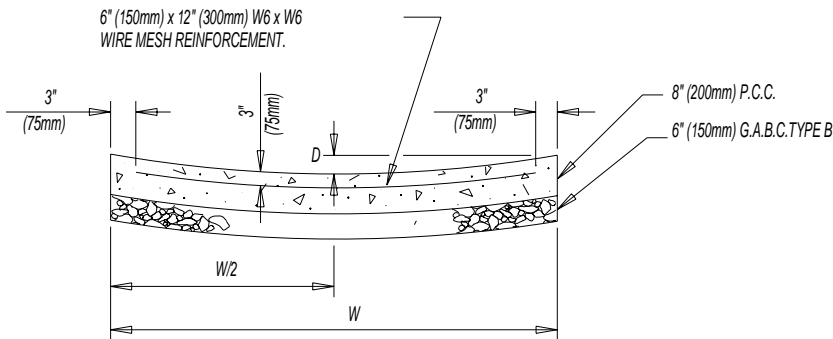

SECTION A-A

P.C.C. VALLEY GUTTER

WIDTH W	DEPTH D	OFFSET S
8' (2.4m)	3" (75mm)	16" (405mm)
4' (1.2m)	1 1/2" (38mm)	23 1/2" (585mm)

CANAL

Contract is for various locations throughout New Castle County.

DETAILS SHEET

SPEED HUMP

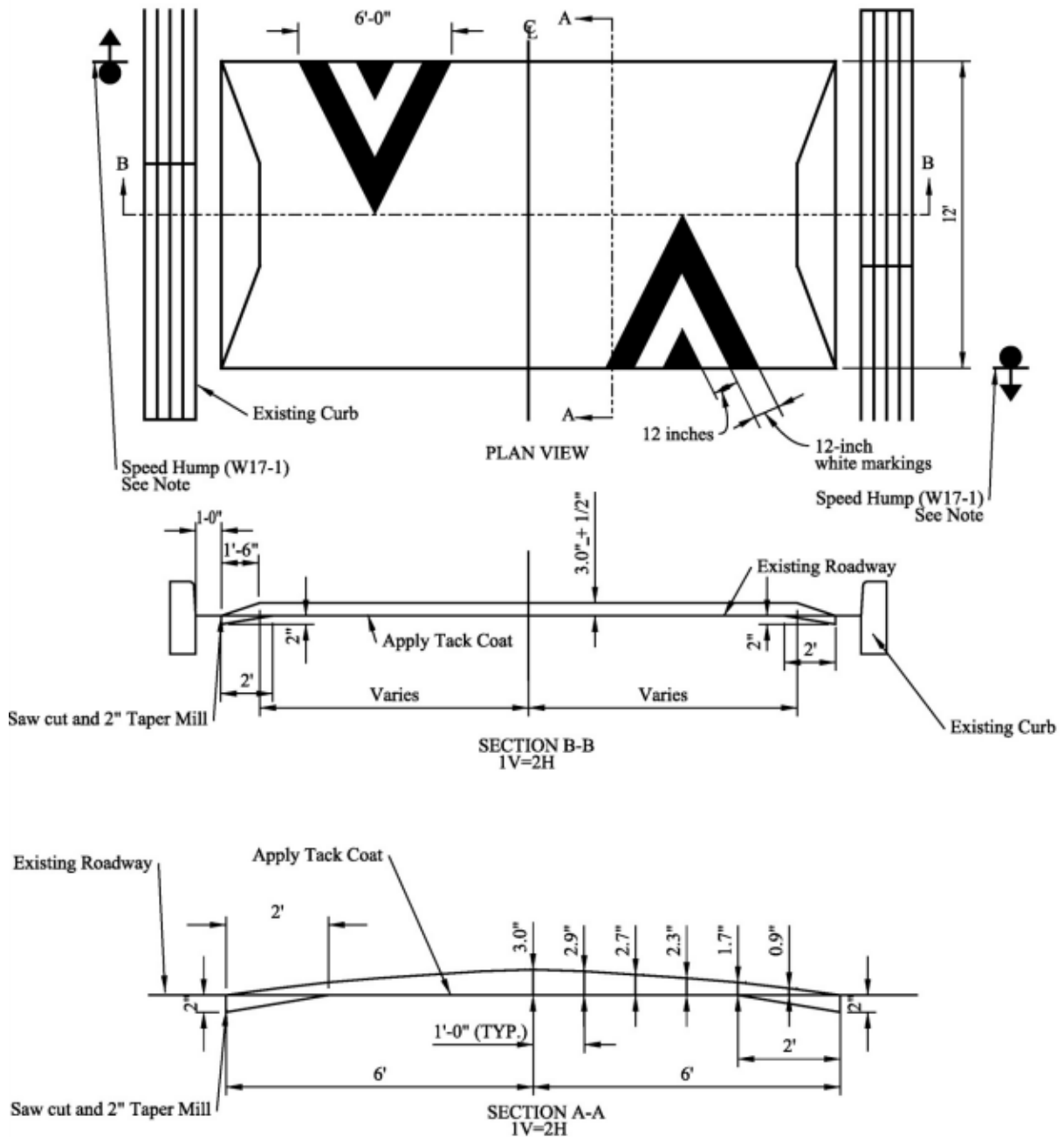

NOTE:  
 1. ALL SIGNING AND STRIPING SHALL CONFORM TO THE LATEST EDITION OF THE DE MUTCD.

DELAWARE DEPARTMENT OF TRANSPORTATION

CONTRACT NUMBER- T202503120

(CAD) PAGE 34 OF 84

CANAL

Contract is for various locations throughout New Castle County.

DETAILS SHEET

REMOVE AND DISPOSE OF EXISTING FRAME AND COVER AS DIRECTED BY OWNER IF NOT UTILIZED IN THE ADJUSTMENT.  
PLACE NEW OR EXISTING FRAME AND COVER (AS REQUIRED).  
TO CORRECT ELEVATION, RECOLLAR AND PLACE BITUMINOUS CONCRETE PATCH. NEW FRAME AND COVER (IF REQUIRED) TO BE PROVIDED BY OWNER.

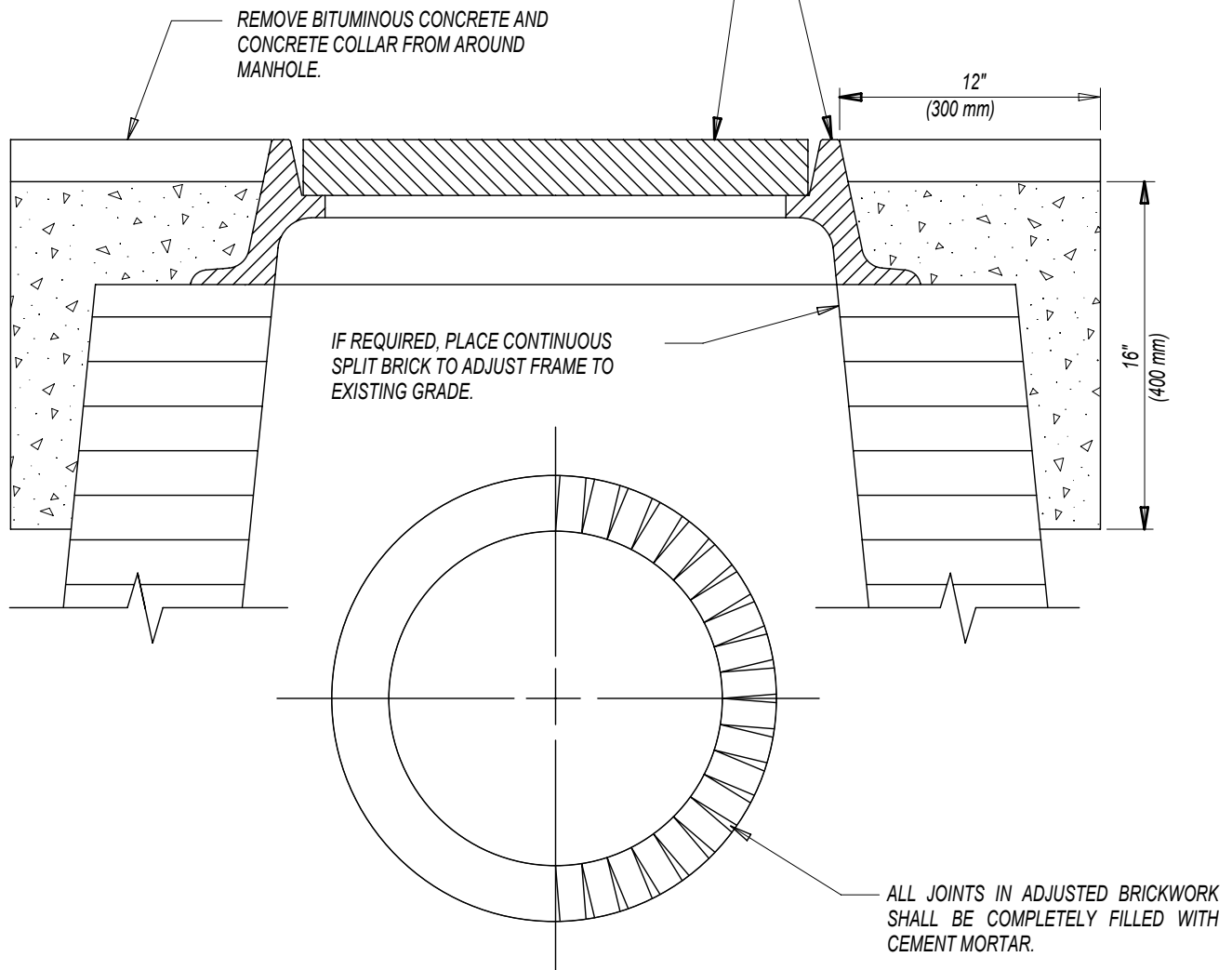

ADJUSTING AND REPAIRING MANHOLE

N.T.S.

NOTE: MANHOLES IN CONCRETE ROADWAYS SHALL BE SAWCUT FULL DEPTH TO THE SPECIFIED DIMENSION PRIOR TO ANY ADJUSTMENT BEING MADE. THE SAWCUTTING SHALL BE INCIDENTAL TO ITEM 602132.

DELAWARE DEPARTMENT OF TRANSPORTATION

CONTRACT NUMBER- T202503120

(CAD) PAGE 35 OF 84

CANAL

Contract is for various locations throughout New Castle County.

DETAILS SHEET

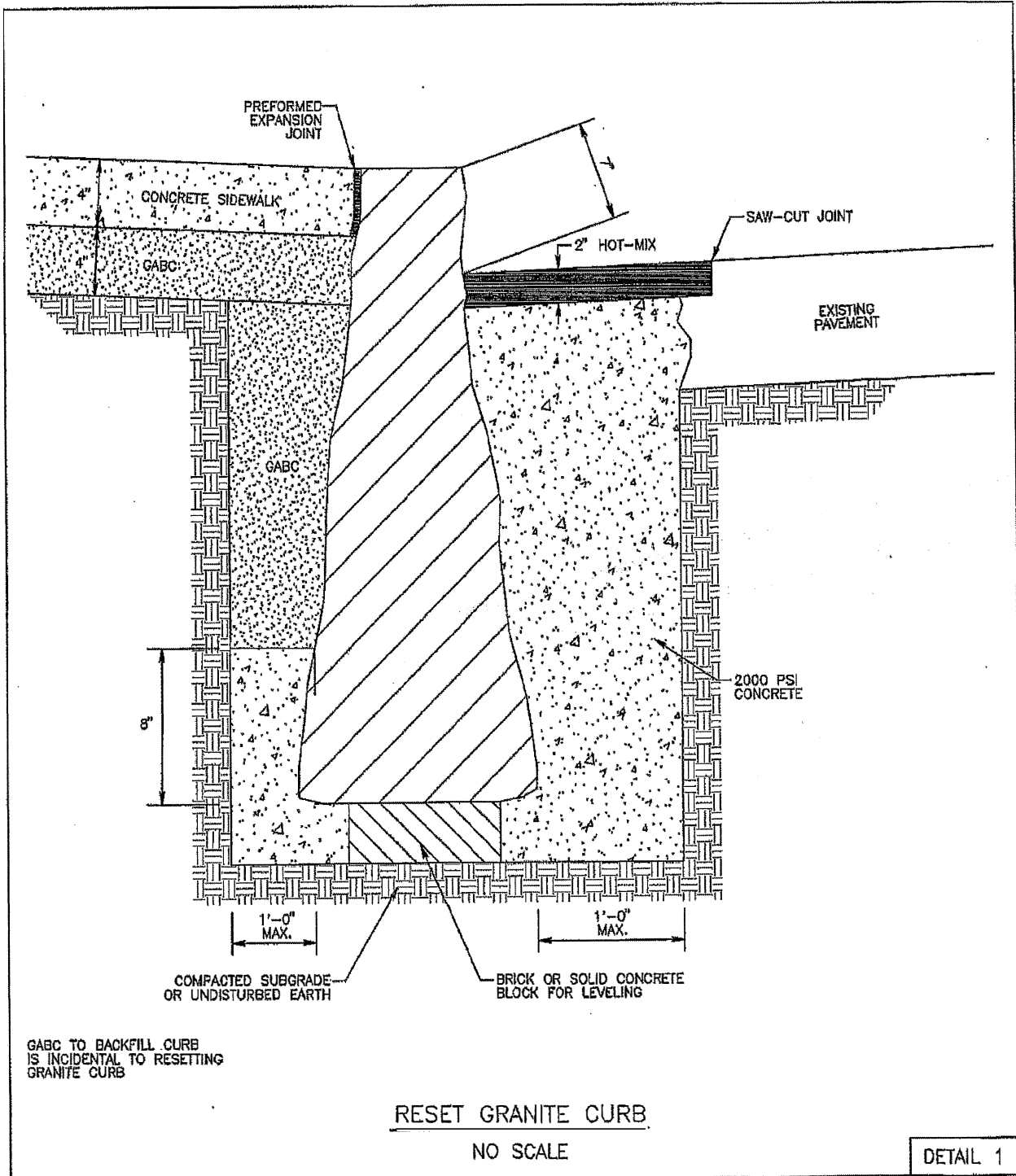

DELAWARE DEPARTMENT OF TRANSPORTATION

CONTRACT T202503120

(CAD) PAGE 36 OF 84

CANAL

COMMUNITY TRANSPORTATION FUND, WILMINGTON, 2025

---

LOCATION 1 BRANDYWINE HILLS - WASHINGTON BLVD FROM 4308 WASHINGTON BLVD.  
TO 4308 WASHINGTON BLVD.

LENGTH  
GENERAL IMPROVEMENTS  
SIDEWALK REPAIRS

COMMENTS:

4308 WASHINGTON BLVD. WILMINGTON, DE 19802. REPLACE SEWER MANHOLE FRAME/LID.

---

MATERIAL ESTIMATE FOR LOCATION 1

202000	EXCAVATION AND EMBANKMENT	1.00	C.Y.
211001	REMOVAL OF PORTLAND CEMENT CONCRETE PAVEMENT, CURB AND SIDEWALK	14.00	S.Y.
301001	GABC	2.00	C.Y.
301002	GABC, PATCHING	1.00	C.Y.
401029	SUPERPAVE TYPE C, PG 64-22, PATCHING	2.00	TON
404001	BITUMINOUS CRACK AND JOINT SEALING LESS THAN 3/4-INCH WIDE	25.00	L.F.
602102	MANHOLE COVER(S)	1.00	EACH
602103	MANHOLE FRAME(S)	1.00	EACH
602132	ADJUSTING AND REPAIRING EXISTING MANHOLE	1.00	EACH
701013	PCC CURB, TYPE 1-8	10.00	L.F.
705001	PCC SIDEWALK, 4"	100.00	S.F.
710002	ADJUST WATER VALVE BOXES	1.00	EACH
762000	SAW CUTTING, BITUMINOUS CONCRETE	15.00	L.F.
762001	SAW CUTTING, CONCRETE, FULL DEPTH	22.00	L.F.
811001	FLAGGER, NEW CASTLE COUNTY	26.00	HOUR
811013	FLAGGER, NEW CASTLE COUNTY, OVERTIME	6.00	HOUR
908001	TOPSOIL	1.00	TON
908016	PERMANENT GRASS SEEDING, SUBDIVISION	2.00	S.Y.
908020	EROSION CONTROL BLANKET MULCH	2.00	S.Y.

DELAWARE DEPARTMENT OF TRANSPORTATION

CONTRACT T202503120

(CAD) PAGE 37 OF 84

CANAL

COMMUNITY TRANSPORTATION FUND, WILMINGTON, 2025

---

LOCATION 2 AUGUSTINE HILLS - STONE HILL ROAD FROM CARL ROAD (INCLUDE INTERSECTION) TO AUGUSTINE CUT OFF

LENGTH 163.6776 m 537.0000 L.F.

GENERAL IMPROVEMENTS

2" MILL AND OVERLAY(CURB WHERE NECESSARY)

COMMENTS:

INCLUDE INT @ CARL.

---

MATERIAL ESTIMATE FOR LOCATION 2

211001	REMOVAL OF PORTLAND CEMENT CONCRETE PAVEMENT, CURB AND SIDEWALK	22.00	S.Y.
301001	GABC	1.00	C.Y.
301002	GABC, PATCHING	2.00	C.Y.
401005	SUPERPAVE TYPE C, PG 64-22 (CARBONATE STONE)	200.00	TON
401029	SUPERPAVE TYPE C, PG 64-22, PATCHING	21.00	TON
401030	SUPERPAVE TYPE B, PG 64-22, PATCHING	50.00	TON
404001	BITUMINOUS CRACK AND JOINT SEALING LESS THAN 3/4-INCH WIDE	58.00	L.F.
602132	ADJUSTING AND REPAIRING EXISTING MANHOLE	2.00	EACH
701013	PCC CURB, TYPE 1-8	100.00	L.F.
710002	ADJUST WATER VALVE BOXES	1.00	EACH
760010	PAVEMENT MILLING, BITUMINOUS CONCRETE PAVEMENT	3,000.00	SY-IN
762000	SAW CUTTING, BITUMINOUS CONCRETE	450.00	L.F.
762001	SAW CUTTING, CONCRETE, FULL DEPTH	18.00	L.F.
802003	ARROW PANELS TYPE C	4.00	EA-DY
808002	PROVIDE AND MAINTAIN TRUCK MOUNTED ATTENUATOR, TYPE II	4.00	EA-DY
811001	FLAGGER, NEW CASTLE COUNTY	101.00	HOUR
811013	FLAGGER, NEW CASTLE COUNTY, OVERTIME	12.00	HOUR
908001	TOPSOIL	4.00	TON
908016	PERMANENT GRASS SEEDING, SUBDIVISION	24.00	S.Y.
908020	EROSION CONTROL BLANKET MULCH	24.00	S.Y.

DELAWARE DEPARTMENT OF TRANSPORTATION

CONTRACT T202503120

(CAD) PAGE 38 OF 84

CANAL

COMMUNITY TRANSPORTATION FUND, WILMINGTON, 2025

---

**LOCATION 3**                      **BELLEFONTE - RODMAN ROAD FROM BRANDYWINE BLVD (CIHM) TO GRANDVIEW AVE (INCLUDE INT)**

LENGTH      152.4000 m                      500.0000 L.F.

**GENERAL IMPROVEMENTS**  
2" MILL AND OVERLAY

**COMMENTS:**

INCLUDE INT @ GRANDVIEW. CIHM @ STOP SIGN @ BRANDYWINE. DO NOT INCLUDE CROSSWALK.

---

**MATERIAL ESTIMATE FOR LOCATION 3**

202000	EXCAVATION AND EMBANKMENT	22.00	C.Y.
401005	SUPERPAVE TYPE C, PG 64-22 (CARBONATE STONE)	220.00	TON
401029	SUPERPAVE TYPE C, PG 64-22, PATCHING	1.00	TON
401030	SUPERPAVE TYPE B, PG 64-22, PATCHING	100.00	TON
404001	BITUMINOUS CRACK AND JOINT SEALING LESS THAN 3/4-INCH WIDE	298.00	L.F.
602100	DRAINAGE INLET GRATE(S)	1.00	EACH
602101	DRAINAGE INLET FRAME(S)	1.00	EACH
602130	ADJUSTING AND REPAIRING EXISTING DRAINAGE INLET	1.00	EACH
602132	ADJUSTING AND REPAIRING EXISTING MANHOLE	2.00	EACH
760010	PAVEMENT MILLING, BITUMINOUS CONCRETE PAVEMENT	3,200.00	SY-IN
762000	SAW CUTTING, BITUMINOUS CONCRETE	250.00	L.F.
811001	FLAGGER, NEW CASTLE COUNTY	120.00	HOUR
811013	FLAGGER, NEW CASTLE COUNTY, OVERTIME	15.00	HOUR
817002	PERMANENT PAVEMENT STRIPING, SYMBOL/LEGEND, ALKYD-THERMOPLASTIC	20.00	S.F.
817004	TEMPORARY MARKINGS, PAINT, SYMBOL/LEGEND	20.00	S.F.
905004	INLET SEDIMENT CONTROL, DRAINAGE INLET	1.00	EACH

**DELAWARE DEPARTMENT OF TRANSPORTATION**

**CONTRACT T202503120**

**(CAD) PAGE 39 OF 84**

**CANAL**

**COMMUNITY TRANSPORTATION FUND, WILMINGTON, 2025**

**LOCATION 4                      CLAYMONT HEIGHTS - PARKSIDE BOULEVARD FROM LINCOLN AVENUE TO  
MC KINLEY AVENUE (INCLUDE INT)**

LENGTH      94.4880 m                                      310.0000 L.F.

**GENERAL IMPROVEMENTS**

2" MILL AND OVERLAY(CURB WHERE NECESSARY)

**COMMENTS:**

INCLUDE INT @ MCKINLEY. 2 RAMPS @ LINCLON. 3 RAMPS @ MCKINLEY.

**MATERIAL ESTIMATE FOR LOCATION 4**

202000	EXCAVATION AND EMBANKMENT	11.00	C.Y.
211001	REMOVAL OF PORTLAND CEMENT CONCRETE PAVEMENT, CURB AND SIDEWALK	55.00	S.Y.
301001	GABC	5.00	C.Y.
301002	GABC, PATCHING	10.00	C.Y.
401005	SUPERPAVE TYPE C, PG 64-22 (CARBONATE STONE)	125.00	TON
401029	SUPERPAVE TYPE C, PG 64-22, PATCHING	32.00	TON
401030	SUPERPAVE TYPE B, PG 64-22, PATCHING	25.00	TON
404001	BITUMINOUS CRACK AND JOINT SEALING LESS THAN 3/4-INCH WIDE	63.00	L.F.
602100	DRAINAGE INLET GRATE(S)	1.00	EACH
602101	DRAINAGE INLET FRAME(S)	1.00	EACH
602130	ADJUSTING AND REPAIRING EXISTING DRAINAGE INLET	2.00	EACH
602132	ADJUSTING AND REPAIRING EXISTING MANHOLE	2.00	EACH
701013	PCC CURB, TYPE 1-8	10.00	L.F.
701019	I.PCC CURB AND GUTTER, TYPE 2	150.00	L.F.
705001	PCC SIDEWALK, 4"	60.00	S.F.
705002	PCC SIDEWALK, 6"	120.00	S.F.
705008	PEDESTRIAN CONNECTION, TYPE 1	150.00	S.F.
705009	PEDESTRIAN CONNECTION, TYPE 2, 3, AND/OR 4	1,000.00	S.F.
705013	TRUNCATED DOME DETECTABLE WARNING SURFACE	50.00	S.F.
710002	ADJUST WATER VALVE BOXES	1.00	EACH
760010	PAVEMENT MILLING, BITUMINOUS CONCRETE PAVEMENT	2,000.00	SY-IN
762000	SAW CUTTING, BITUMINOUS CONCRETE	225.00	L.F.
762001	SAW CUTTING, CONCRETE, FULL DEPTH	23.00	L.F.
811001	FLAGGER, NEW CASTLE COUNTY	135.00	HOUR
811013	FLAGGER, NEW CASTLE COUNTY, OVERTIME	16.00	HOUR

DELAWARE DEPARTMENT OF TRANSPORTATION

CONTRACT T202503120

(CAD) PAGE 40 OF 84

CANAL

COMMUNITY TRANSPORTATION FUND, WILMINGTON, 2025

---

**LOCATION 4**                      **CLAYMONT HEIGHTS - PARKSIDE BOULEVARD FROM LINCOLN AVENUE TO  
MC KINLEY AVENUE (INCLUDE INT)**

LENGTH      94.4880 m                      310.0000 L.F.

**GENERAL IMPROVEMENTS**

2" MILL AND OVERLAY(CURB WHERE NECESSARY)

**COMMENTS:**

INCLUDE INT @ McKINLEY. 2 RAMPS @ LINCLON. 3 RAMPS @ McKINLEY.

---

**MATERIAL ESTIMATE FOR LOCATION 4**

905004	INLET SEDIMENT CONTROL, DRAINAGE INLET	3.00	EACH
908001	TOPSOIL	26.00	TON
908016	PERMANENT GRASS SEEDING, SUBDIVISION	156.00	S.Y.
908020	EROSION CONTROL BLANKET MULCH	156.00	S.Y.

**DELAWARE DEPARTMENT OF TRANSPORTATION**

**CONTRACT T202503120**

**(CAD) PAGE 41 OF 84**

**CANAL**

**COMMUNITY TRANSPORTATION FUND, WILMINGTON, 2025**

**LOCATION 5 FAIRFAX - PINEHURST ROAD FROM JULIAN ROAD TO FAIRFAX BLVD**

**LENGTH 202.6920 m 665.0000 L.F.**

**GENERAL IMPROVEMENTS**

**2" MILL AND OVERLAY(CURB WHERE NECESSARY)**

**COMMENTS:**

**2 RAMPS @ FAIRFAX.**

**MATERIAL ESTIMATE FOR LOCATION 5**

202000	EXCAVATION AND EMBANKMENT	27.00	C.Y.
211001	REMOVAL OF PORTLAND CEMENT CONCRETE PAVEMENT, CURB AND SIDEWALK	199.00	S.Y.
301001	GABC	15.00	C.Y.
301002	GABC, PATCHING	34.00	C.Y.
401005	SUPERPAVE TYPE C, PG 64-22 (CARBONATE STONE)	250.00	TON
401029	SUPERPAVE TYPE C, PG 64-22, PATCHING	112.00	TON
401030	SUPERPAVE TYPE B, PG 64-22, PATCHING	50.00	TON
404001	BITUMINOUS CRACK AND JOINT SEALING LESS THAN 3/4-INCH WIDE	155.00	L.F.
602100	DRAINAGE INLET GRATE(S)	1.00	EACH
602101	DRAINAGE INLET FRAME(S)	1.00	EACH
602130	ADJUSTING AND REPAIRING EXISTING DRAINAGE INLET	2.00	EACH
701013	PCC CURB, TYPE 1-8	4.00	L.F.
701019	I.PCC CURB AND GUTTER, TYPE 2	550.00	L.F.
705001	PCC SIDEWALK, 4"	220.00	S.F.
705002	PCC SIDEWALK, 6"	440.00	S.F.
705008	PEDESTRIAN CONNECTION, TYPE 1	60.00	S.F.
705009	PEDESTRIAN CONNECTION, TYPE 2, 3, AND/OR 4	400.00	S.F.
705013	TRUNCATED DOME DETECTABLE WARNING SURFACE	20.00	S.F.
710370	STEEL CASING PIPE, 4"	20.00	L.F.
760010	PAVEMENT MILLING, BITUMINOUS CONCRETE PAVEMENT	3,400.00	SY-IN
762000	SAW CUTTING, BITUMINOUS CONCRETE	825.00	L.F.
762001	SAW CUTTING, CONCRETE, FULL DEPTH	83.00	L.F.
811001	FLAGGER, NEW CASTLE COUNTY	211.00	HOUR
811013	FLAGGER, NEW CASTLE COUNTY, OVERTIME	23.00	HOUR
905004	INLET SEDIMENT CONTROL, DRAINAGE INLET	3.00	EACH
908001	TOPSOIL	30.00	TON

DELAWARE DEPARTMENT OF TRANSPORTATION

CONTRACT T202503120

(CAD) PAGE 42 OF 84

CANAL

COMMUNITY TRANSPORTATION FUND, WILMINGTON, 2025

---

LOCATION 5 FAIRFAX - PINEHURST ROAD FROM JULIAN ROAD TO FAIRFAX BLVD

LENGTH 202.6920 m 665.0000 L.F.

GENERAL IMPROVEMENTS

2" MILL AND OVERLAY(CURB WHERE NECESSARY)

COMMENTS:

2 RAMPS @ FAIRFAX.

---

MATERIAL ESTIMATE FOR LOCATION 5

908016	PERMANENT GRASS SEEDING, SUBDIVISION	180.00	S.Y.
908020	EROSION CONTROL BLANKET MULCH	180.00	S.Y.



**DELAWARE DEPARTMENT OF TRANSPORTATION**

**CONTRACT T202503120**

**(CAD) PAGE 44 OF 84**

**CANAL**

**COMMUNITY TRANSPORTATION FUND, WILMINGTON, 2025**

---

**LOCATION 6**                      **FOULK WOODS - LONGWOOD DRIVE FROM DEEPWOOD DR (CIHM) TO  
EATON RD**

**LENGTH**      85.3440 m                      280.0000 L.F.

**GENERAL IMPROVEMENTS**

2" MILL AND OVERLAY(CURB WHERE NECESSARY)

**COMMENTS:**

2 RAMPS @ DEEPWOOD. 2 RAMPS @ EATON.

---

**MATERIAL ESTIMATE FOR LOCATION 6**

**908020      EROSION CONTROL BLANKET MULCH**

**132.00      S.Y.**

DELAWARE DEPARTMENT OF TRANSPORTATION

CONTRACT T202503120

(CAD) PAGE 45 OF 84

CANAL

COMMUNITY TRANSPORTATION FUND, WILMINGTON, 2025

---

LOCATION 7                      FOULK WOODS - LONGWOOD DRIVE FROM LITTLE LEAF CT TO DEEPWOOD  
DR (CIHM)

LENGTH      537.9720 m                      1765.0000 L.F.

**GENERAL IMPROVEMENTS**

2" MILL AND OVERLAY(CURB WHERE NECESSARY)

COMMENTS:

---

MATERIAL ESTIMATE FOR LOCATION 7

202000	EXCAVATION AND EMBANKMENT	35.00	C.Y.
211001	REMOVAL OF PORTLAND CEMENT CONCRETE PAVEMENT, CURB AND SIDEWALK	306.00	S.Y.
301001	GABC	21.00	C.Y.
301002	GABC, PATCHING	51.00	C.Y.
401005	SUPERPAVE TYPE C, PG 64-22 (CARBONATE STONE)	550.00	TON
401029	SUPERPAVE TYPE C, PG 64-22, PATCHING	171.00	TON
401030	SUPERPAVE TYPE B, PG 64-22, PATCHING	50.00	TON
401506	SPEED HUMP	66.00	L.F.
404001	BITUMINOUS CRACK AND JOINT SEALING LESS THAN 3/4-INCH WIDE	365.00	L.F.
602130	ADJUSTING AND REPAIRING EXISTING DRAINAGE INLET	7.00	EACH
602131	ADJUSTING AND REPAIRING EXISTING DOUBLE DRAINAGE INLET	1.00	EACH
602132	ADJUSTING AND REPAIRING EXISTING MANHOLE	2.00	EACH
701019	I.PCC CURB AND GUTTER, TYPE 2	850.00	L.F.
705001	PCC SIDEWALK, 4"	340.00	S.F.
705002	PCC SIDEWALK, 6"	680.00	S.F.
760010	PAVEMENT MILLING, BITUMINOUS CONCRETE PAVEMENT	8,700.00	SY-IN
762000	SAW CUTTING, BITUMINOUS CONCRETE	1,275.00	L.F.
762001	SAW CUTTING, CONCRETE, FULL DEPTH	128.00	L.F.
811001	FLAGGER, NEW CASTLE COUNTY	437.00	HOUR
811013	FLAGGER, NEW CASTLE COUNTY, OVERTIME	47.00	HOUR
905004	INLET SEDIMENT CONTROL, DRAINAGE INLET	10.00	EACH
908001	TOPSOIL	34.00	TON
908016	PERMANENT GRASS SEEDING, SUBDIVISION	204.00	S.Y.
908020	EROSION CONTROL BLANKET MULCH	204.00	S.Y.

DELAWARE DEPARTMENT OF TRANSPORTATION

CONTRACT T202503120

(CAD) PAGE 46 OF 84

CANAL

COMMUNITY TRANSPORTATION FUND, WILMINGTON, 2025

---

**LOCATION 8**                      **GREEN ACRES - NEWCOMB ROAD FROM ATHENS RD (CIHM) TO EMORY RD (CIHM)**

LENGTH      236.2200 m                      775.0000 L.F.

**GENERAL IMPROVEMENTS**

2" MILL AND OVERLAY (CURB WHERE NECESSARY)

**COMMENTS:**

ONLY PAVE REMAINING SECTIONS OF NEWCOMB LEFT UNPAVED AFTER VEOLIA (BCCI) COMPLETED WORK. 2 RAMPS @ EMORY.

---

**MATERIAL ESTIMATE FOR LOCATION 8**

202000	EXCAVATION AND EMBANKMENT	7.00	C.Y.
211001	REMOVAL OF PORTLAND CEMENT CONCRETE PAVEMENT, CURB AND SIDEWALK	1.00	S.Y.
301001	GABC	1.00	C.Y.
301002	GABC, PATCHING	1.00	C.Y.
401005	SUPERPAVE TYPE C, PG 64-22 (CARBONATE STONE)	140.00	TON
401029	SUPERPAVE TYPE C, PG 64-22, PATCHING	2.00	TON
401030	SUPERPAVE TYPE B, PG 64-22, PATCHING	25.00	TON
404001	BITUMINOUS CRACK AND JOINT SEALING LESS THAN 3/4-INCH WIDE	900.00	L.F.
602132	ADJUSTING AND REPAIRING EXISTING MANHOLE	3.00	EACH
701013	PCC CURB, TYPE 1-8	4.00	L.F.
705008	PEDESTRIAN CONNECTION, TYPE 1	60.00	S.F.
705009	PEDESTRIAN CONNECTION, TYPE 2, 3, AND/OR 4	400.00	S.F.
705013	TRUNCATED DOME DETECTABLE WARNING SURFACE	20.00	S.F.
710002	ADJUST WATER VALVE BOXES	1.00	EACH
760010	PAVEMENT MILLING, BITUMINOUS CONCRETE PAVEMENT	2,000.00	SY-IN
811001	FLAGGER, NEW CASTLE COUNTY	80.00	HOUR
811013	FLAGGER, NEW CASTLE COUNTY, OVERTIME	10.00	HOUR
908001	TOPSOIL	8.00	TON
908016	PERMANENT GRASS SEEDING, SUBDIVISION	48.00	S.Y.
908020	EROSION CONTROL BLANKET MULCH	48.00	S.Y.



DELAWARE DEPARTMENT OF TRANSPORTATION

CONTRACT T202503120

(CAD) PAGE 48 OF 84

CANAL

COMMUNITY TRANSPORTATION FUND, WILMINGTON, 2025

---

LOCATION 10 MAYFIELD - CELINA COURT FROM WINSTEAD ROAD TO CUL-DE-SAC

LENGTH 28.9560 m 95.0000 L.F.

GENERAL IMPROVEMENTS

2" MILL AND OVERLAY(CURB WHERE NECESSARY)

COMMENTS:

2 RAMPS @ WINSTEAD

---

MATERIAL ESTIMATE FOR LOCATION 10

211001	REMOVAL OF PORTLAND CEMENT CONCRETE PAVEMENT, CURB AND SIDEWALK	95.00	S.Y.
301001	GABC	9.00	C.Y.
301002	GABC, PATCHING	12.00	C.Y.
401005	SUPERPAVE TYPE C, PG 64-22 (CARBONATE STONE)	90.00	TON
401029	SUPERPAVE TYPE C, PG 64-22, PATCHING	36.00	TON
401030	SUPERPAVE TYPE B, PG 64-22, PATCHING	5.00	TON
404001	BITUMINOUS CRACK AND JOINT SEALING LESS THAN 3/4-INCH WIDE	109.00	L.F.
501001	PCC PAVEMENT, 8"	48.00	S.Y.
701013	PCC CURB, TYPE 1-8	4.00	L.F.
701019	I.PCC CURB AND GUTTER, TYPE 2	130.00	L.F.
705001	PCC SIDEWALK, 4"	52.00	S.F.
705002	PCC SIDEWALK, 6"	104.00	S.F.
705009	PEDESTRIAN CONNECTION, TYPE 2, 3, AND/OR 4	400.00	S.F.
705013	TRUNCATED DOME DETECTABLE WARNING SURFACE	20.00	S.F.
760010	PAVEMENT MILLING, BITUMINOUS CONCRETE PAVEMENT	470.00	SY-IN
760011	PAVEMENT MILLING, BITUMINOUS CONCRETE PAVEMENT, TAPER CUT	430.00	SY-IN
762000	SAW CUTTING, BITUMINOUS CONCRETE	339.00	L.F.
762001	SAW CUTTING, CONCRETE, FULL DEPTH	34.00	L.F.
811001	FLAGGER, NEW CASTLE COUNTY	76.00	HOUR
811013	FLAGGER, NEW CASTLE COUNTY, OVERTIME	7.00	HOUR
908001	TOPSOIL	17.00	TON
908016	PERMANENT GRASS SEEDING, SUBDIVISION	102.00	S.Y.
908020	EROSION CONTROL BLANKET MULCH	102.00	S.Y.

**DELAWARE DEPARTMENT OF TRANSPORTATION**

**CONTRACT T202503120**

**(CAD) PAGE 49 OF 84**

**CANAL**

**COMMUNITY TRANSPORTATION FUND, WILMINGTON, 2025**

**LOCATION 11 MAYFIELD - WINSTEAD FROM MAYFIELD RD TO WEBSTER DR**

**LENGTH 350.5200 m 1150.0000 L.F.**

**GENERAL IMPROVEMENTS**

2" MILL AND OVERLAY(CURB WHERE NECESSARY)

**COMMENTS:**

2 RAMPS @ MAYFIELD, 2 RAMPS @ WALTON, 2 RAMPS @ WEBSTER

**MATERIAL ESTIMATE FOR LOCATION 11**

211001	REMOVAL OF PORTLAND CEMENT CONCRETE PAVEMENT, CURB AND SIDEWALK	224.00	S.Y.
301001	GABC	16.00	C.Y.
301002	GABC, PATCHING	37.00	C.Y.
401005	SUPERPAVE TYPE C, PG 64-22 (CARBONATE STONE)	355.00	TON
401029	SUPERPAVE TYPE C, PG 64-22, PATCHING	124.00	TON
401030	SUPERPAVE TYPE B, PG 64-22, PATCHING	58.00	TON
404001	BITUMINOUS CRACK AND JOINT SEALING LESS THAN 3/4-INCH WIDE	86.00	L.F.
602100	DRAINAGE INLET GRATE(S)	4.00	EACH
602101	DRAINAGE INLET FRAME(S)	2.00	EACH
602130	ADJUSTING AND REPAIRING EXISTING DRAINAGE INLET	1.00	EACH
602131	ADJUSTING AND REPAIRING EXISTING DOUBLE DRAINAGE INLET	4.00	EACH
602132	ADJUSTING AND REPAIRING EXISTING MANHOLE	1.00	EACH
701013	PCC CURB, TYPE 1-8	12.00	L.F.
701019	I.PCC CURB AND GUTTER, TYPE 2	620.00	L.F.
705001	PCC SIDEWALK, 4"	248.00	S.F.
705002	PCC SIDEWALK, 6"	496.00	S.F.
705009	PEDESTRIAN CONNECTION, TYPE 2, 3, AND/OR 4	1,200.00	S.F.
705013	TRUNCATED DOME DETECTABLE WARNING SURFACE	60.00	S.F.
710002	ADJUST WATER VALVE BOXES	4.00	EACH
760010	PAVEMENT MILLING, BITUMINOUS CONCRETE PAVEMENT	5,630.00	SY-IN
762000	SAW CUTTING, BITUMINOUS CONCRETE	930.00	L.F.
762001	SAW CUTTING, CONCRETE, FULL DEPTH	93.00	L.F.
811001	FLAGGER, NEW CASTLE COUNTY	327.00	HOUR
811013	FLAGGER, NEW CASTLE COUNTY, OVERTIME	33.00	HOUR
905004	INLET SEDIMENT CONTROL, DRAINAGE INLET	5.00	EACH
908001	TOPSOIL	49.00	TON

**DELAWARE DEPARTMENT OF TRANSPORTATION**

**CONTRACT T202503120**

**(CAD) PAGE 50 OF 84**

**CANAL**

**COMMUNITY TRANSPORTATION FUND, WILMINGTON, 2025**

---

**LOCATION 11 MAYFIELD - WINSTEAD FROM MAYFIELD RD TO WEBSTER DR**

**LENGTH 350.5200 m 1150.0000 L.F.**

**GENERAL IMPROVEMENTS**

**2" MILL AND OVERLAY(CURB WHERE NECESSARY)**

**COMMENTS:**

**2 RAMPS @ MAYFIELD, 2 RAMPS @ WALTON, 2 RAMPS @ WEBSTER**

---

**MATERIAL ESTIMATE FOR LOCATION 11**

<b>908016</b>	<b>PERMANENT GRASS SEEDING, SUBDIVISION</b>	<b>293.00</b>	<b>S.Y.</b>
<b>908020</b>	<b>EROSION CONTROL BLANKET MULCH</b>	<b>293.00</b>	<b>S.Y.</b>

**DELAWARE DEPARTMENT OF TRANSPORTATION**

**CONTRACT T202503120**

**(CAD) PAGE 51 OF 84**

**CANAL**

COMMUNITY TRANSPORTATION FUND, WILMINGTON, 2025

**LOCATION 12 MC DANIEL CREST - SHELLPOT DRIVE FROM CONCORD AVENUE (INCLUDE INT) TO GOODLEY ROAD (INCLUDE INT)**

LENGTH 106.6800 m 350.0000 L.F.

**GENERAL IMPROVEMENTS**

2" MILL AND OVERLAY(CURB WHERE NECESSARY)

**COMMENTS:**

INCLUDE BOTH INTS. 1 RAMP @ GOODLEY.

**MATERIAL ESTIMATE FOR LOCATION 12**

202000	EXCAVATION AND EMBANKMENT	11.00	C.Y.
211001	REMOVAL OF PORTLAND CEMENT CONCRETE PAVEMENT, CURB AND SIDEWALK	55.00	S.Y.
301001	GABC	5.00	C.Y.
301002	GABC, PATCHING	10.00	C.Y.
401005	SUPERPAVE TYPE C, PG 64-22 (CARBONATE STONE)	150.00	TON
401029	SUPERPAVE TYPE C, PG 64-22, PATCHING	32.00	TON
401030	SUPERPAVE TYPE B, PG 64-22, PATCHING	25.00	TON
404001	BITUMINOUS CRACK AND JOINT SEALING LESS THAN 3/4-INCH WIDE	163.00	L.F.
602132	ADJUSTING AND REPAIRING EXISTING MANHOLE	2.00	EACH
701013	PCC CURB, TYPE 1-8	2.00	L.F.
701019	I.PCC CURB AND GUTTER, TYPE 2	150.00	L.F.
705001	PCC SIDEWALK, 4"	60.00	S.F.
705002	PCC SIDEWALK, 6"	120.00	S.F.
705008	PEDESTRIAN CONNECTION, TYPE 1	30.00	S.F.
705009	PEDESTRIAN CONNECTION, TYPE 2, 3, AND/OR 4	200.00	S.F.
705013	TRUNCATED DOME DETECTABLE WARNING SURFACE	10.00	S.F.
710002	ADJUST WATER VALVE BOXES	2.00	EACH
760010	PAVEMENT MILLING, BITUMINOUS CONCRETE PAVEMENT	2,000.00	SY-IN
762000	SAW CUTTING, BITUMINOUS CONCRETE	225.00	L.F.
762001	SAW CUTTING, CONCRETE, FULL DEPTH	23.00	L.F.
811001	FLAGGER, NEW CASTLE COUNTY	96.00	HOUR
811013	FLAGGER, NEW CASTLE COUNTY, OVERTIME	11.00	HOUR
908001	TOPSOIL	10.00	TON
908016	PERMANENT GRASS SEEDING, SUBDIVISION	60.00	S.Y.
908020	EROSION CONTROL BLANKET MULCH	60.00	S.Y.

DELAWARE DEPARTMENT OF TRANSPORTATION

CONTRACT T202503120

(CAD) PAGE 52 OF 84

CANAL

COMMUNITY TRANSPORTATION FUND, WILMINGTON, 2025

---

LOCATION 13 MC DANIEL CREST - SHELLPOT DRIVE FROM DUNCAN AVENUE TO  
LYNDHURST AVENUE (INCLUDE INT)

LENGTH 76.2000 m 250.0000 L.F.

**GENERAL IMPROVEMENTS**

2" MILL AND OVERLAY(CURB WHERE NECESSARY)

**COMMENTS:**

INCLUDE INT @ LYNDHURST.

---

**MATERIAL ESTIMATE FOR LOCATION 13**

202000	EXCAVATION AND EMBANKMENT	10.00	C.Y.
211001	REMOVAL OF PORTLAND CEMENT CONCRETE PAVEMENT, CURB AND SIDEWALK	54.00	S.Y.
301001	GABC	4.00	C.Y.
301002	GABC, PATCHING	9.00	C.Y.
401005	SUPERPAVE TYPE C, PG 64-22 (CARBONATE STONE)	100.00	TON
401029	SUPERPAVE TYPE C, PG 64-22, PATCHING	31.00	TON
401030	SUPERPAVE TYPE B, PG 64-22, PATCHING	25.00	TON
404001	BITUMINOUS CRACK AND JOINT SEALING LESS THAN 3/4-INCH WIDE	113.00	L.F.
602132	ADJUSTING AND REPAIRING EXISTING MANHOLE	2.00	EACH
701019	I.PCC CURB AND GUTTER, TYPE 2	150.00	L.F.
705001	PCC SIDEWALK, 4"	60.00	S.F.
705002	PCC SIDEWALK, 6"	120.00	S.F.
710002	ADJUST WATER VALVE BOXES	1.00	EACH
760010	PAVEMENT MILLING, BITUMINOUS CONCRETE PAVEMENT	1,300.00	SY-IN
762000	SAW CUTTING, BITUMINOUS CONCRETE	225.00	L.F.
762001	SAW CUTTING, CONCRETE, FULL DEPTH	23.00	L.F.
811001	FLAGGER, NEW CASTLE COUNTY	69.00	HOURL
811013	FLAGGER, NEW CASTLE COUNTY, OVERTIME	9.00	HOURL
908001	TOPSOIL	6.00	TON
908016	PERMANENT GRASS SEEDING, SUBDIVISION	36.00	S.Y.
908020	EROSION CONTROL BLANKET MULCH	36.00	S.Y.

**DELAWARE DEPARTMENT OF TRANSPORTATION**

**CONTRACT T202503120**

**(CAD) PAGE 53 OF 84**

**CANAL**

**COMMUNITY TRANSPORTATION FUND, WILMINGTON, 2025**

**LOCATION 14 MC DANIEL CREST - SHELLPOT DRIVE FROM GOODLEY ROAD TO DUNCAN AVENUE (INCLUDE INT)**

**LENGTH 86.8680 m 285.0000 L.F.**

**GENERAL IMPROVEMENTS**

**2" MILL AND OVERLAY(CURB WHERE NECESSARY)**

**COMMENTS:**

1 PANEL V.G. @ DUNCAN.

**MATERIAL ESTIMATE FOR LOCATION 14**

202000	EXCAVATION AND EMBANKMENT	14.00	C.Y.
211001	REMOVAL OF PORTLAND CEMENT CONCRETE PAVEMENT, CURB AND SIDEWALK	100.00	S.Y.
301001	GABC	7.00	C.Y.
301002	GABC, PATCHING	16.00	C.Y.
401005	SUPERPAVE TYPE C, PG 64-22 (CARBONATE STONE)	100.00	TON
401029	SUPERPAVE TYPE C, PG 64-22, PATCHING	53.00	TON
401030	SUPERPAVE TYPE B, PG 64-22, PATCHING	25.00	TON
404001	BITUMINOUS CRACK AND JOINT SEALING LESS THAN 3/4-INCH WIDE	143.00	L.F.
501001	PCC PAVEMENT, 8"	10.00	S.Y.
602130	ADJUSTING AND REPAIRING EXISTING DRAINAGE INLET	1.00	EACH
602132	ADJUSTING AND REPAIRING EXISTING MANHOLE	2.00	EACH
701019	I.PCC CURB AND GUTTER, TYPE 2	250.00	L.F.
705001	PCC SIDEWALK, 4"	100.00	S.F.
705002	PCC SIDEWALK, 6"	200.00	S.F.
710002	ADJUST WATER VALVE BOXES	1.00	EACH
760010	PAVEMENT MILLING, BITUMINOUS CONCRETE PAVEMENT	1,400.00	SY-IN
762000	SAW CUTTING, BITUMINOUS CONCRETE	405.00	L.F.
762001	SAW CUTTING, CONCRETE, FULL DEPTH	41.00	L.F.
811001	FLAGGER, NEW CASTLE COUNTY	97.00	HOUR
811013	FLAGGER, NEW CASTLE COUNTY, OVERTIME	13.00	HOUR
905004	INLET SEDIMENT CONTROL, DRAINAGE INLET	2.00	EACH
908001	TOPSOIL	11.00	TON
908016	PERMANENT GRASS SEEDING, SUBDIVISION	65.00	S.Y.
908020	EROSION CONTROL BLANKET MULCH	65.00	S.Y.

DELAWARE DEPARTMENT OF TRANSPORTATION

CONTRACT T202503120

(CAD) PAGE 54 OF 84

CANAL

COMMUNITY TRANSPORTATION FUND, WILMINGTON, 2025

---

LOCATION 15 NORTH HILLS - LENNOX AND WINDSOR FROM LENNOX RD BETWEEN 515 AND 517 TO WINDSOR RD IN FRONT OF 12

LENGTH  
GENERAL IMPROVEMENTS  
SPEED HUMPS

COMMENTS:

2 SPEED HUMPS; 1 ON LENNOX RD BETWEEN 510 AND 512. 1 IN FRONT OF 12 WINDSOR RD.

---

MATERIAL ESTIMATE FOR LOCATION 15

401506	SPEED HUMP	42.00	L.F.
404001	BITUMINOUS CRACK AND JOINT SEALING LESS THAN 3/4-INCH WIDE	100.00	L.F.
811001	FLAGGER, NEW CASTLE COUNTY	25.00	HOUR
811013	FLAGGER, NEW CASTLE COUNTY, OVERTIME	3.00	HOUR

**DELAWARE DEPARTMENT OF TRANSPORTATION**

**CONTRACT T202503120**

**(CAD) PAGE 55 OF 84**

**CANAL**

**COMMUNITY TRANSPORTATION FUND, WILMINGTON, 2025**

**LOCATION 16 PEMBREY - PEMBREY PLACE FROM PEMBREY DRIVE EAST TO FOULK ROAD**

**LENGTH 143.2560 m 470.0000 L.F.**

**GENERAL IMPROVEMENTS**

2" MILL AND OVERLAY(CURB WHERE NECESSARY)

**COMMENTS:**

2 RAMPS @ FOULK.

**MATERIAL ESTIMATE FOR LOCATION 16**

202000	EXCAVATION AND EMBANKMENT	8.00	C.Y.
211001	REMOVAL OF PORTLAND CEMENT CONCRETE PAVEMENT, CURB AND SIDEWALK	12.00	S.Y.
301001	GABC	2.00	C.Y.
301002	GABC, PATCHING	2.00	C.Y.
401005	SUPERPAVE TYPE C, PG 64-22 (CARBONATE STONE)	300.00	TON
401029	SUPERPAVE TYPE C, PG 64-22, PATCHING	12.00	TON
401030	SUPERPAVE TYPE B, PG 64-22, PATCHING	25.00	TON
404001	BITUMINOUS CRACK AND JOINT SEALING LESS THAN 3/4-INCH WIDE	203.00	L.F.
602132	ADJUSTING AND REPAIRING EXISTING MANHOLE	2.00	EACH
701013	PCC CURB, TYPE 1-8	54.00	L.F.
705008	PEDESTRIAN CONNECTION, TYPE 1	60.00	S.F.
705009	PEDESTRIAN CONNECTION, TYPE 2, 3, AND/OR 4	400.00	S.F.
705013	TRUNCATED DOME DETECTABLE WARNING SURFACE	20.00	S.F.
760010	PAVEMENT MILLING, BITUMINOUS CONCRETE PAVEMENT	4,400.00	SY-IN
762000	SAW CUTTING, BITUMINOUS CONCRETE	175.00	L.F.
762001	SAW CUTTING, CONCRETE, FULL DEPTH	9.00	L.F.
802003	ARROW PANELS TYPE C	2.00	EA-DY
808002	PROVIDE AND MAINTAIN TRUCK MOUNTED ATTENUATOR, TYPE II	2.00	EA-DY
811001	FLAGGER, NEW CASTLE COUNTY	215.00	HOUR
811013	FLAGGER, NEW CASTLE COUNTY, OVERTIME	25.00	HOUR
817002	PERMANENT PAVEMENT STRIPING, SYMBOL/LEGEND, ALKYD-THERMOPLASTIC	750.00	S.F.
817003	TEMPORARY MARKINGS, PAINT, 4"	50.00	L.F.
817004	TEMPORARY MARKINGS, PAINT, SYMBOL/LEGEND	750.00	S.F.
817042	PERMANENT PAVEMENT STRIPING, EPOXY RESIN PAINT, WHITE/YELLOW, 6"	50.00	L.F.
846001	PROVIDE AND INSTALL LOOP WIRE 1-CONDUCTOR #14 AWG ENCASED IN 1/4" FLEXIBLE TUBING IN A LOOP SAWCUT	220.00	L.F.

DELAWARE DEPARTMENT OF TRANSPORTATION

CONTRACT T202503120

(CAD) PAGE 56 OF 84

CANAL

COMMUNITY TRANSPORTATION FUND, WILMINGTON, 2025

---

**LOCATION 16**                      **PEMBREY - PEMBREY PLACE FROM PEMBREY DRIVE EAST TO FOULK ROAD**

LENGTH    143.2560 m                      470.0000 L.F.

**GENERAL IMPROVEMENTS**

2" MILL AND OVERLAY(CURB WHERE NECESSARY)

**COMMENTS:**

2 RAMPS @ FOULK.

---

**MATERIAL ESTIMATE FOR LOCATION 16**

908001	TOPSOIL	10.00	TON
908016	PERMANENT GRASS SEEDING, SUBDIVISION	60.00	S.Y.
908020	EROSION CONTROL BLANKET MULCH	60.00	S.Y.

**DELAWARE DEPARTMENT OF TRANSPORTATION**

**CONTRACT T202503120**

**(CAD) PAGE 57 OF 84**

**CANAL**

**COMMUNITY TRANSPORTATION FUND, WILMINGTON, 2025**

**LOCATION 17 PRESIDENTIAL ESTATES - BEGIN PL FROM CHAPEL CREST LN TO CAMP DAVID RD**

LENGTH 73.1520 m 240.0000 L.F.

**GENERAL IMPROVEMENTS**

2" MILL AND OVERLAY(CURB WHERE NECESSARY)

**COMMENTS:**

2 RAMPS @ CAMP DAVID. 2 RAMPS @ CHAPEL CREST

**MATERIAL ESTIMATE FOR LOCATION 17**

211001	REMOVAL OF PORTLAND CEMENT CONCRETE PAVEMENT, CURB AND SIDEWALK	19.00	S.Y.
301001	GABC	2.00	C.Y.
301002	GABC, PATCHING	4.00	C.Y.
401005	SUPERPAVE TYPE C, PG 64-22 (CARBONATE STONE)	75.00	TON
401029	SUPERPAVE TYPE C, PG 64-22, PATCHING	12.00	TON
401030	SUPERPAVE TYPE B, PG 64-22, PATCHING	10.00	TON
404001	BITUMINOUS CRACK AND JOINT SEALING LESS THAN 3/4-INCH WIDE	5.00	L.F.
602130	ADJUSTING AND REPAIRING EXISTING DRAINAGE INLET	1.00	EACH
701013	PCC CURB, TYPE 1-8	8.00	L.F.
701019	I.PCC CURB AND GUTTER, TYPE 2	50.00	L.F.
705001	PCC SIDEWALK, 4"	20.00	S.F.
705002	PCC SIDEWALK, 6"	40.00	S.F.
705008	PEDESTRIAN CONNECTION, TYPE 1	120.00	S.F.
705009	PEDESTRIAN CONNECTION, TYPE 2, 3, AND/OR 4	800.00	S.F.
705013	TRUNCATED DOME DETECTABLE WARNING SURFACE	40.00	S.F.
760010	PAVEMENT MILLING, BITUMINOUS CONCRETE PAVEMENT	1,200.00	SY-IN
762000	SAW CUTTING, BITUMINOUS CONCRETE	75.00	L.F.
762001	SAW CUTTING, CONCRETE, FULL DEPTH	8.00	L.F.
811001	FLAGGER, NEW CASTLE COUNTY	74.00	HOUR
811013	FLAGGER, NEW CASTLE COUNTY, OVERTIME	8.00	HOUR
905004	INLET SEDIMENT CONTROL, DRAINAGE INLET	2.00	EACH
908001	TOPSOIL	18.00	TON
908016	PERMANENT GRASS SEEDING, SUBDIVISION	108.00	S.Y.
908020	EROSION CONTROL BLANKET MULCH	108.00	S.Y.

**DELAWARE DEPARTMENT OF TRANSPORTATION**

**CONTRACT T202503120**

**(CAD) PAGE 58 OF 84**

**CANAL**

**COMMUNITY TRANSPORTATION FUND, WILMINGTON, 2025**

**LOCATION 18 PRESIDENTIAL ESTATES - CAMP DAVID ROAD FROM CUL-DE-SAC TO CUL-DE-SAC**

LENGTH 257.5560 m 845.0000 L.F.

**GENERAL IMPROVEMENTS**

2" MILL AND OVERLAY(CURB WHERE NECESSARY)

**COMMENTS:**

**MATERIAL ESTIMATE FOR LOCATION 18**

211001	REMOVAL OF PORTLAND CEMENT CONCRETE PAVEMENT, CURB AND SIDEWALK	19.00	S.Y.
301001	GABC	2.00	C.Y.
301002	GABC, PATCHING	4.00	C.Y.
401005	SUPERPAVE TYPE C, PG 64-22 (CARBONATE STONE)	350.00	TON
401029	SUPERPAVE TYPE C, PG 64-22, PATCHING	12.00	TON
401030	SUPERPAVE TYPE B, PG 64-22, PATCHING	30.00	TON
404001	BITUMINOUS CRACK AND JOINT SEALING LESS THAN 3/4-INCH WIDE	125.00	L.F.
602131	ADJUSTING AND REPAIRING EXISTING DOUBLE DRAINAGE INLET	1.00	EACH
602132	ADJUSTING AND REPAIRING EXISTING MANHOLE	5.00	EACH
701013	PCC CURB, TYPE 1-8	4.00	L.F.
701019	I.PCC CURB AND GUTTER, TYPE 2	50.00	L.F.
705001	PCC SIDEWALK, 4"	20.00	S.F.
705002	PCC SIDEWALK, 6"	40.00	S.F.
705008	PEDESTRIAN CONNECTION, TYPE 1	60.00	S.F.
705009	PEDESTRIAN CONNECTION, TYPE 2, 3, AND/OR 4	400.00	S.F.
705013	TRUNCATED DOME DETECTABLE WARNING SURFACE	20.00	S.F.
760010	PAVEMENT MILLING, BITUMINOUS CONCRETE PAVEMENT	3,500.00	SY-IN
760011	PAVEMENT MILLING, BITUMINOUS CONCRETE PAVEMENT, TAPER CUT	1,000.00	SY-IN
762000	SAW CUTTING, BITUMINOUS CONCRETE	75.00	L.F.
762001	SAW CUTTING, CONCRETE, FULL DEPTH	8.00	L.F.
811001	FLAGGER, NEW CASTLE COUNTY	156.00	HOUR
811013	FLAGGER, NEW CASTLE COUNTY, OVERTIME	18.00	HOUR
905004	INLET SEDIMENT CONTROL, DRAINAGE INLET	3.00	EACH
908001	TOPSOIL	10.00	TON
908016	PERMANENT GRASS SEEDING, SUBDIVISION	60.00	S.Y.

**DELAWARE DEPARTMENT OF TRANSPORTATION**

**CONTRACT T202503120**

**(CAD) PAGE 59 OF 84**

**CANAL**

**COMMUNITY TRANSPORTATION FUND, WILMINGTON, 2025**

---

**LOCATION 18                      PRESIDENTIAL ESTATES - CAMP DAVID ROAD FROM CUL-DE-SAC TO CUL-DE-SAC**

**LENGTH      257.5560 m                      845.0000 L.F.**

**GENERAL IMPROVEMENTS**

**2" MILL AND OVERLAY(CURB WHERE NECESSARY)**

**COMMENTS:**

---

**MATERIAL ESTIMATE FOR LOCATION 18**

**908020      EROSION CONTROL BLANKET MULCH**

**60.00      S.Y.**

**DELAWARE DEPARTMENT OF TRANSPORTATION**

**CONTRACT T202503120**

**(CAD) PAGE 60 OF 84**

**CANAL**

**COMMUNITY TRANSPORTATION FUND, WILMINGTON, 2025**

**LOCATION 19 SURREY PARK - STABLE LN FROM STABLE CT TO COACHMAN RD**

**LENGTH 298.7040 m 980.0000 L.F.**

**GENERAL IMPROVEMENTS**

2" MILL AND OVERLAY(CURB WHERE NECESSARY)

**COMMENTS:**

**MATERIAL ESTIMATE FOR LOCATION 19**

211001	REMOVAL OF PORTLAND CEMENT CONCRETE PAVEMENT, CURB AND SIDEWALK	202.00	S.Y.
301001	GABC	14.00	C.Y.
301002	GABC, PATCHING	34.00	C.Y.
401005	SUPERPAVE TYPE C, PG 64-22 (CARBONATE STONE)	305.00	TON
401029	SUPERPAVE TYPE C, PG 64-22, PATCHING	112.00	TON
401030	SUPERPAVE TYPE B, PG 64-22, PATCHING	50.00	TON
404001	BITUMINOUS CRACK AND JOINT SEALING LESS THAN 3/4-INCH WIDE	152.00	L.F.
602130	ADJUSTING AND REPAIRING EXISTING DRAINAGE INLET	2.00	EACH
602132	ADJUSTING AND REPAIRING EXISTING MANHOLE	4.00	EACH
701019	I.PCC CURB AND GUTTER, TYPE 2	560.00	L.F.
705001	PCC SIDEWALK, 4"	224.00	S.F.
705002	PCC SIDEWALK, 6"	448.00	S.F.
760010	PAVEMENT MILLING, BITUMINOUS CONCRETE PAVEMENT	4,800.00	SY-IN
762000	SAW CUTTING, BITUMINOUS CONCRETE	840.00	L.F.
762001	SAW CUTTING, CONCRETE, FULL DEPTH	84.00	L.F.
811001	FLAGGER, NEW CASTLE COUNTY	228.00	HOUR
811013	FLAGGER, NEW CASTLE COUNTY, OVERTIME	23.00	HOUR
905004	INLET SEDIMENT CONTROL, DRAINAGE INLET	2.00	EACH
908001	TOPSOIL	22.00	TON
908016	PERMANENT GRASS SEEDING, SUBDIVISION	134.00	S.Y.
908020	EROSION CONTROL BLANKET MULCH	134.00	S.Y.

**DELAWARE DEPARTMENT OF TRANSPORTATION**

**CONTRACT T202503120**

**(CAD) PAGE 61 OF 84**

**CANAL**

**COMMUNITY TRANSPORTATION FUND, WILMINGTON, 2025**

**LOCATION 20 VALLEY RUN - BASSWOOD LANE FROM VALLEY RD TO CUL DE SAC**

**LENGTH 71.6280 m 235.0000 L.F.**

**GENERAL IMPROVEMENTS**

**2" MILL AND OVERLAY(CURB WHERE NECESSARY)**

**COMMENTS:**

**MATERIAL ESTIMATE FOR LOCATION 20**

211001	REMOVAL OF PORTLAND CEMENT CONCRETE PAVEMENT, CURB AND SIDEWALK	144.00	S.Y.
301001	GABC	10.00	C.Y.
301002	GABC, PATCHING	24.00	C.Y.
401005	SUPERPAVE TYPE C, PG 64-22 (CARBONATE STONE)	125.00	TON
401029	SUPERPAVE TYPE C, PG 64-22, PATCHING	81.00	TON
401030	SUPERPAVE TYPE B, PG 64-22, PATCHING	10.00	TON
404001	BITUMINOUS CRACK AND JOINT SEALING LESS THAN 3/4-INCH WIDE	64.00	L.F.
602132	ADJUSTING AND REPAIRING EXISTING MANHOLE	1.00	EACH
701019	I.PCC CURB AND GUTTER, TYPE 2	400.00	L.F.
705001	PCC SIDEWALK, 4"	160.00	S.F.
705002	PCC SIDEWALK, 6"	320.00	S.F.
710002	ADJUST WATER VALVE BOXES	1.00	EACH
760010	PAVEMENT MILLING, BITUMINOUS CONCRETE PAVEMENT	1,000.00	SY-IN
760011	PAVEMENT MILLING, BITUMINOUS CONCRETE PAVEMENT, TAPER CUT	500.00	SY-IN
762000	SAW CUTTING, BITUMINOUS CONCRETE	600.00	L.F.
762001	SAW CUTTING, CONCRETE, FULL DEPTH	60.00	L.F.
811001	FLAGGER, NEW CASTLE COUNTY	106.00	HOUR
811013	FLAGGER, NEW CASTLE COUNTY, OVERTIME	13.00	HOUR
908001	TOPSOIL	16.00	TON
908016	PERMANENT GRASS SEEDING, SUBDIVISION	96.00	S.Y.
908020	EROSION CONTROL BLANKET MULCH	96.00	S.Y.

DELAWARE DEPARTMENT OF TRANSPORTATION

CONTRACT T202503120

(CAD) PAGE 62 OF 84

CANAL

COMMUNITY TRANSPORTATION FUND, WILMINGTON, 2025

---

LOCATION 21 WILMINGTON - N. VAN BUREN STREET. FROM 600 N. VAN BUREN ST. TO 600 N. VAN BUREN ST.

LENGTH

GENERAL IMPROVEMENTS  
SIDEWALK REPAIRS

COMMENTS:

6' X 20' SIDEWALK. LEAVE TREE PIT.

---

MATERIAL ESTIMATE FOR LOCATION 21

211001	REMOVAL OF PORTLAND CEMENT CONCRETE PAVEMENT, CURB AND SIDEWALK	14.00	S.Y.
301001	GABC	1.00	C.Y.
705001	PCC SIDEWALK, 4"	120.00	S.F.
762001	SAW CUTTING, CONCRETE, FULL DEPTH	24.00	L.F.
811001	FLAGGER, NEW CASTLE COUNTY	19.00	HOUR
811013	FLAGGER, NEW CASTLE COUNTY, OVERTIME	2.00	HOUR

DELAWARE DEPARTMENT OF TRANSPORTATION

CONTRACT T202503120

(CAD) PAGE 63 OF 84

CANAL

COMMUNITY TRANSPORTATION FUND, WILMINGTON, 2025

---

LOCATION 22 WILMINGTON - 4TH STREET FROM 1205 4TH STREET TO 1221 4TH STREET  
LENGTH  
GENERAL IMPROVEMENTS  
SIDEWALK REPAIRS

COMMENTS:

1205(ALLEY) - 1209 = 35' X 9', 20' X 5'. 1217-1221 = 51' X 9'.

---

MATERIAL ESTIMATE FOR LOCATION 22

211001	REMOVAL OF PORTLAND CEMENT CONCRETE PAVEMENT, CURB AND SIDEWALK	108.00	S.Y.
301001	GABC	11.00	C.Y.
705001	PCC SIDEWALK, 4"	900.00	S.F.
710002	ADJUST WATER VALVE BOXES	10.00	EACH
762001	SAW CUTTING, CONCRETE, FULL DEPTH	180.00	L.F.
811001	FLAGGER, NEW CASTLE COUNTY	164.00	HOUR
811013	FLAGGER, NEW CASTLE COUNTY, OVERTIME	15.00	HOUR

DELAWARE DEPARTMENT OF TRANSPORTATION

CONTRACT T202503120

(CAD) PAGE 64 OF 84

CANAL

COMMUNITY TRANSPORTATION FUND, WILMINGTON, 2025

---

LOCATION 23 WILMINGTON - BROWN STREET FROM 136 7TH AVE TO 136 7TH AVE  
LENGTH  
GENERAL IMPROVEMENTS  
SIDEWALK REPAIRS

COMMENTS:

SIDEWALK/CURB/RAMP REPAIRS @ NW CORNER OF 7TH AVE & BROWN STREET.

---

MATERIAL ESTIMATE FOR LOCATION 23

211001	REMOVAL OF PORTLAND CEMENT CONCRETE PAVEMENT, CURB AND SIDEWALK	53.00	S.Y.
301001	GABC	10.00	C.Y.
301002	GABC, PATCHING	5.00	C.Y.
401029	SUPERPAVE TYPE C, PG 64-22, PATCHING	4.00	TON
404001	BITUMINOUS CRACK AND JOINT SEALING LESS THAN 3/4-INCH WIDE	5.00	L.F.
602130	ADJUSTING AND REPAIRING EXISTING DRAINAGE INLET	1.00	EACH
602131	ADJUSTING AND REPAIRING EXISTING DOUBLE DRAINAGE INLET	1.00	EACH
701013	PCC CURB, TYPE 1-8	52.00	L.F.
705001	PCC SIDEWALK, 4"	250.00	S.F.
705008	PEDESTRIAN CONNECTION, TYPE 1	30.00	S.F.
705009	PEDESTRIAN CONNECTION, TYPE 2, 3, AND/OR 4	200.00	S.F.
705013	TRUNCATED DOME DETECTABLE WARNING SURFACE	10.00	S.F.
705504	BRICK AND/OR BLOCK SIDEWALK	200.00	S.F.
710002	ADJUST WATER VALVE BOXES	1.00	EACH
762000	SAW CUTTING, BITUMINOUS CONCRETE	75.00	L.F.
762001	SAW CUTTING, CONCRETE, FULL DEPTH	59.00	L.F.
811001	FLAGGER, NEW CASTLE COUNTY	80.00	HOUR
811013	FLAGGER, NEW CASTLE COUNTY, OVERTIME	10.00	HOUR
819018	INSTALLATION OR REMOVAL OF TRAFFIC SIGN(S) ON SINGLE SIGN POST	2.00	EACH
819023	GALVANIZED TELESCOPING STEEL SIGNPOSTS, 15'X2", COMPLETE W/BASEPOSTS & HARDWARE	1.00	EACH
905004	INLET SEDIMENT CONTROL, DRAINAGE INLET	3.00	EACH
908001	TOPSOIL	8.00	TON
908016	PERMANENT GRASS SEEDING, SUBDIVISION	48.00	S.Y.
908020	EROSION CONTROL BLANKET MULCH	48.00	S.Y.

DELAWARE DEPARTMENT OF TRANSPORTATION

CONTRACT T202503120

(CAD) PAGE 65 OF 84

CANAL

COMMUNITY TRANSPORTATION FUND, WILMINGTON, 2025

---

**LOCATION 24**                      **WILMINGTON - CHESTNUT STREET FROM 1019 CHESTNUT STREET TO 1019 CHESTNUT STREET**

LENGTH      15.2400 m                      50.0000 L.F.

**GENERAL IMPROVEMENTS**  
    SIDEWALK REPAIRS

**COMMENTS:**

    CONCRETE SIDEWALK @ 1019. STUMP REMOVAL

---

**MATERIAL ESTIMATE FOR LOCATION 24**

211001	REMOVAL OF PORTLAND CEMENT CONCRETE PAVEMENT, CURB AND SIDEWALK	54.00	S.Y.
211510	STUMP REMOVAL	2.00	L.F.
301001	GABC	5.00	C.Y.
701501	RESET EXISTING STONE CURB	20.00	L.F.
705001	PCC SIDEWALK, 4"	450.00	S.F.
710002	ADJUST WATER VALVE BOXES	3.00	EACH
762001	SAW CUTTING, CONCRETE, FULL DEPTH	90.00	L.F.
811001	FLAGGER, NEW CASTLE COUNTY	78.00	HOUR
811013	FLAGGER, NEW CASTLE COUNTY, OVERTIME	8.00	HOUR

DELAWARE DEPARTMENT OF TRANSPORTATION

CONTRACT T202503120

(CAD) PAGE 66 OF 84

CANAL

COMMUNITY TRANSPORTATION FUND, WILMINGTON, 2025

---

LOCATION 25 WILMINGTON - N DUPONT ST. FROM 818 N DUPONT ST. WILMINGTON TO 824  
N DUPONT ST. WILMINGTON

LENGTH

GENERAL IMPROVEMENTS

SIDEWALK REPAIRS

COMMENTS:

N DUPONT ST. WILMINGTON, DE 19805

---

MATERIAL ESTIMATE FOR LOCATION 25

211001	REMOVAL OF PORTLAND CEMENT CONCRETE PAVEMENT, CURB AND SIDEWALK	38.00	S.Y.
301001	GABC	4.00	C.Y.
705001	PCC SIDEWALK, 4"	315.00	S.F.
710002	ADJUST WATER VALVE BOXES	1.00	EACH
762001	SAW CUTTING, CONCRETE, FULL DEPTH	63.00	L.F.
811001	FLAGGER, NEW CASTLE COUNTY	52.00	HOUR
811013	FLAGGER, NEW CASTLE COUNTY, OVERTIME	6.00	HOUR

**DELAWARE DEPARTMENT OF TRANSPORTATION**

**CONTRACT T202503120**

**(CAD) PAGE 67 OF 84**

**CANAL**

**COMMUNITY TRANSPORTATION FUND, WILMINGTON, 2025**

**LOCATION 26 WILMINGTON - N PINE ST. FROM 5TH ST TO 6TH ST**

**LENGTH 82.2960 m 270.0000 L.F.**

**GENERAL IMPROVEMENTS**

2" MILL AND OVERLAY(CURB WHERE NECESSARY)

**COMMENTS:**

INCLUDE PARKING LOT. 2 RAMPS @ 5TH ST.

**MATERIAL ESTIMATE FOR LOCATION 26**

202000	EXCAVATION AND EMBANKMENT	7.00	C.Y.
211001	REMOVAL OF PORTLAND CEMENT CONCRETE PAVEMENT, CURB AND SIDEWALK	1.00	S.Y.
301001	GABC	1.00	C.Y.
301002	GABC, PATCHING	1.00	C.Y.
401005	SUPERPAVE TYPE C, PG 64-22 (CARBONATE STONE)	150.00	TON
401029	SUPERPAVE TYPE C, PG 64-22, PATCHING	2.00	TON
401030	SUPERPAVE TYPE B, PG 64-22, PATCHING	25.00	TON
404001	BITUMINOUS CRACK AND JOINT SEALING LESS THAN 3/4-INCH WIDE	74.00	L.F.
602130	ADJUSTING AND REPAIRING EXISTING DRAINAGE INLET	1.00	EACH
602132	ADJUSTING AND REPAIRING EXISTING MANHOLE	1.00	EACH
701013	PCC CURB, TYPE 1-8	4.00	L.F.
705008	PEDESTRIAN CONNECTION, TYPE 1	60.00	S.F.
705009	PEDESTRIAN CONNECTION, TYPE 2, 3, AND/OR 4	400.00	S.F.
705013	TRUNCATED DOME DETECTABLE WARNING SURFACE	20.00	S.F.
710002	ADJUST WATER VALVE BOXES	3.00	EACH
760010	PAVEMENT MILLING, BITUMINOUS CONCRETE PAVEMENT	2,200.00	SY-IN
811001	FLAGGER, NEW CASTLE COUNTY	98.00	HOUR
811013	FLAGGER, NEW CASTLE COUNTY, OVERTIME	13.00	HOUR
817002	PERMANENT PAVEMENT STRIPING, SYMBOL/LEGEND, ALKYD-THERMOPLASTIC	50.00	S.F.
817003	TEMPORARY MARKINGS, PAINT, 4"	300.00	L.F.
817004	TEMPORARY MARKINGS, PAINT, SYMBOL/LEGEND	50.00	S.F.
817042	PERMANENT PAVEMENT STRIPING, EPOXY RESIN PAINT, WHITE/YELLOW, 6"	300.00	L.F.
905004	INLET SEDIMENT CONTROL, DRAINAGE INLET	1.00	EACH
908001	TOPSOIL	8.00	TON
908016	PERMANENT GRASS SEEDING, SUBDIVISION	48.00	S.Y.
908020	EROSION CONTROL BLANKET MULCH	48.00	S.Y.

**DELAWARE DEPARTMENT OF TRANSPORTATION**

**CONTRACT T202503120**

**(CAD) PAGE 68 OF 84**

**CANAL**

**COMMUNITY TRANSPORTATION FUND, WILMINGTON, 2025**

---

**LOCATION 26 WILMINGTON - N PINE ST. FROM 5TH ST TO 6TH ST**

**LENGTH 82.2960 m 270.0000 L.F.**

**GENERAL IMPROVEMENTS**

**2" MILL AND OVERLAY(CURB WHERE NECESSARY)**

**COMMENTS:**

**INCLUDE PARKING LOT. 2 RAMPS @ 5TH ST.**

---

**MATERIAL ESTIMATE FOR LOCATION 26**

DELAWARE DEPARTMENT OF TRANSPORTATION

CONTRACT T202503120

(CAD) PAGE 69 OF 84

CANAL

COMMUNITY TRANSPORTATION FUND, WILMINGTON, 2025

---

**LOCATION 27**                      **WILMINGTON - 26 W 20TH ST FROM 26 W 20TH ST TO 26 W 20TH ST**  
LENGTH    11.5824 m                      38.0000 L.F.  
**GENERAL IMPROVEMENTS**  
                    SIDEWALK REPAIRS

**COMMENTS:**

REPAIR SIDEWALK ADJACENT TO TATNALL ST NEAR TREE. NORTH SIDE OF 26 W 20TH ST.  
LEAVE CONCRETE AT LEAST 6' FROM TREE. REPAIR 2 PANELS ON 20TH ST.

---

**MATERIAL ESTIMATE FOR LOCATION 27**

211001	REMOVAL OF PORTLAND CEMENT CONCRETE PAVEMENT, CURB AND SIDEWALK	72.00	S.Y.
301001	GABC	7.00	C.Y.
705001	PCC SIDEWALK, 4"	600.00	S.F.
762001	SAW CUTTING, CONCRETE, FULL DEPTH	120.00	L.F.
811001	FLAGGER, NEW CASTLE COUNTY	96.00	HOUR
811013	FLAGGER, NEW CASTLE COUNTY, OVERTIME	10.00	HOUR

DELAWARE DEPARTMENT OF TRANSPORTATION

CONTRACT T202503120

(CAD) PAGE 70 OF 84

CANAL

COMMUNITY TRANSPORTATION FUND, WILMINGTON, 2025

---

**LOCATION 28**                      **WILMINGTON - FRANKLIN PL FROM 801 W. 32ND ST. TO 801 W. 32ND ST.**  
LENGTH    21.9456 m                      72.0000 L.F.  
**GENERAL IMPROVEMENTS**  
                    SIDEWALK REPAIRS

**COMMENTS:**

1 RAMP @ CORNER OF FRANKLIN PL & W. 32ND ST. APPROX. 70 LF SIDEWALK AT SIDE OF HOUSE @ 801 W. 32ND ST.

---

**MATERIAL ESTIMATE FOR LOCATION 28**

202000	EXCAVATION AND EMBANKMENT	1.00	C.Y.
211001	REMOVAL OF PORTLAND CEMENT CONCRETE PAVEMENT, CURB AND SIDEWALK	44.00	S.Y.
301001	GABC	5.00	C.Y.
301002	GABC, PATCHING	1.00	C.Y.
401029	SUPERPAVE TYPE C, PG 64-22, PATCHING	1.00	TON
701013	PCC CURB, TYPE 1-8	2.00	L.F.
705001	PCC SIDEWALK, 4"	360.00	S.F.
705008	PEDESTRIAN CONNECTION, TYPE 1	30.00	S.F.
705009	PEDESTRIAN CONNECTION, TYPE 2, 3, AND/OR 4	200.00	S.F.
705013	TRUNCATED DOME DETECTABLE WARNING SURFACE	10.00	S.F.
762001	SAW CUTTING, CONCRETE, FULL DEPTH	72.00	L.F.
811001	FLAGGER, NEW CASTLE COUNTY	66.00	HOUR
811013	FLAGGER, NEW CASTLE COUNTY, OVERTIME	7.00	HOUR
908001	TOPSOIL	4.00	TON
908016	PERMANENT GRASS SEEDING, SUBDIVISION	24.00	S.Y.
908020	EROSION CONTROL BLANKET MULCH	24.00	S.Y.

DELAWARE DEPARTMENT OF TRANSPORTATION

CONTRACT T202503120

(CAD) PAGE 71 OF 84

CANAL

COMMUNITY TRANSPORTATION FUND, WILMINGTON, 2025

---

**LOCATION 29**                      **WILMINGTON - N WEST ST. FROM 2006 N WEST ST TO 2006 N WEST ST**  
LENGTH    7.6200 m                      25.0000 L.F.  
**GENERAL IMPROVEMENTS**  
                    SIDEWALK REPAIRS

COMMENTS:

---

**MATERIAL ESTIMATE FOR LOCATION 29**

211001	REMOVAL OF PORTLAND CEMENT CONCRETE PAVEMENT, CURB AND SIDEWALK	21.00	S.Y.
301001	GABC	3.00	C.Y.
301002	GABC, PATCHING	1.00	C.Y.
401029	SUPERPAVE TYPE C, PG 64-22, PATCHING	5.00	TON
404001	BITUMINOUS CRACK AND JOINT SEALING LESS THAN 3/4-INCH WIDE	3.00	L.F.
701010	PCC CURB, TYPE 1-2	25.00	L.F.
705001	PCC SIDEWALK, 4"	125.00	S.F.
710002	ADJUST WATER VALVE BOXES	1.00	EACH
762000	SAW CUTTING, BITUMINOUS CONCRETE	38.00	L.F.
762001	SAW CUTTING, CONCRETE, FULL DEPTH	30.00	L.F.
811001	FLAGGER, NEW CASTLE COUNTY	26.00	HOUR
811013	FLAGGER, NEW CASTLE COUNTY, OVERTIME	4.00	HOUR
908001	TOPSOIL	1.00	TON
908016	PERMANENT GRASS SEEDING, SUBDIVISION	6.00	S.Y.
908020	EROSION CONTROL BLANKET MULCH	6.00	S.Y.

DELAWARE DEPARTMENT OF TRANSPORTATION

CONTRACT T202503120

(CAD) PAGE 72 OF 84

CANAL

COMMUNITY TRANSPORTATION FUND, WILMINGTON, 2025

---

LOCATION 30 WILMINGTON - W 22ND ST FROM 204 W 22ND ST TO 204 W 22ND ST

LENGTH 3.0480 m 10.0000 L.F.

GENERAL IMPROVEMENTS

SIDEWALK REPAIRS

COMMENTS:

---

MATERIAL ESTIMATE FOR LOCATION 30

211001	REMOVAL OF PORTLAND CEMENT CONCRETE PAVEMENT, CURB AND SIDEWALK	12.00	S.Y.
301001	GABC	1.00	C.Y.
705001	PCC SIDEWALK, 4"	100.00	S.F.
762001	SAW CUTTING, CONCRETE, FULL DEPTH	20.00	L.F.
811001	FLAGGER, NEW CASTLE COUNTY	16.00	HOUR
811013	FLAGGER, NEW CASTLE COUNTY, OVERTIME	2.00	HOUR

DELAWARE DEPARTMENT OF TRANSPORTATION

CONTRACT T202503120

(CAD) PAGE 73 OF 84

CANAL

COMMUNITY TRANSPORTATION FUND, WILMINGTON, 2025

---

LOCATION 31 WILMINGTON - W 22ND ST FROM 216 W 22ND ST TO 216 W 22ND ST  
LENGTH 6.7056 m 22.0000 L.F.  
GENERAL IMPROVEMENTS  
SIDEWALK REPAIRS

COMMENTS:

RAISE GRANITE CURB

---

MATERIAL ESTIMATE FOR LOCATION 31

211001	REMOVAL OF PORTLAND CEMENT CONCRETE PAVEMENT, CURB AND SIDEWALK	24.00	S.Y.
301001	GABC	2.00	C.Y.
701501	RESET EXISTING STONE CURB	6.00	L.F.
705001	PCC SIDEWALK, 4"	200.00	S.F.
710002	ADJUST WATER VALVE BOXES	1.00	EACH
762001	SAW CUTTING, CONCRETE, FULL DEPTH	40.00	L.F.
811001	FLAGGER, NEW CASTLE COUNTY	34.00	HOUR
811013	FLAGGER, NEW CASTLE COUNTY, OVERTIME	4.00	HOUR

DELAWARE DEPARTMENT OF TRANSPORTATION

CONTRACT T202503120

(CAD) PAGE 74 OF 84

CANAL

COMMUNITY TRANSPORTATION FUND, WILMINGTON, 2025

---

LOCATION 32 WILMINGTON - W 22ND ST FROM 221 W 22ND ST TO 221 W 22ND ST  
LENGTH 4.8768 m 16.0000 L.F.  
GENERAL IMPROVEMENTS  
SIDEWALK REPAIRS

COMMENTS:

---

MATERIAL ESTIMATE FOR LOCATION 32

211001	REMOVAL OF PORTLAND CEMENT CONCRETE PAVEMENT, CURB AND SIDEWALK	16.00	S.Y.
301001	GABC	2.00	C.Y.
705001	PCC SIDEWALK, 4"	130.00	S.F.
710002	ADJUST WATER VALVE BOXES	1.00	EACH
762001	SAW CUTTING, CONCRETE, FULL DEPTH	26.00	L.F.
811001	FLAGGER, NEW CASTLE COUNTY	23.00	HOUR
811013	FLAGGER, NEW CASTLE COUNTY, OVERTIME	3.00	HOUR

DELAWARE DEPARTMENT OF TRANSPORTATION

CONTRACT T202503120

(CAD) PAGE 75 OF 84

CANAL

COMMUNITY TRANSPORTATION FUND, WILMINGTON, 2025

---

LOCATION 33 WILMINGTON - W 29TH ST. FROM 432 W 29TH ST. TO 434 W 29TH ST.  
LENGTH 15.5448 m 51.0000 L.F.  
GENERAL IMPROVEMENTS  
SIDEWALK REPAIRS

COMMENTS:

---

MATERIAL ESTIMATE FOR LOCATION 33

211001	REMOVAL OF PORTLAND CEMENT CONCRETE PAVEMENT, CURB AND SIDEWALK	31.00	S.Y.
301001	GABC	3.00	C.Y.
705001	PCC SIDEWALK, 4"	260.00	S.F.
710002	ADJUST WATER VALVE BOXES	2.00	EACH
762001	SAW CUTTING, CONCRETE, FULL DEPTH	52.00	L.F.
811001	FLAGGER, NEW CASTLE COUNTY	46.00	HOUR
811013	FLAGGER, NEW CASTLE COUNTY, OVERTIME	5.00	HOUR

DELAWARE DEPARTMENT OF TRANSPORTATION

CONTRACT T202503120

(CAD) PAGE 76 OF 84

CANAL

COMMUNITY TRANSPORTATION FUND, WILMINGTON, 2025

---

LOCATION 34 WILMINGTON - W 34TH STREET FROM 135 W. 34TH ST. WILMINGTON TO 139 W. 34TH ST. WILMINGTON

LENGTH 12.1920 m 40.0000 L.F.

GENERAL IMPROVEMENTS  
SIDEWALK/CURB REPAIRS

COMMENTS:

---

MATERIAL ESTIMATE FOR LOCATION 34

211001	REMOVAL OF PORTLAND CEMENT CONCRETE PAVEMENT, CURB AND SIDEWALK	41.00	S.Y.
301001	GABC	3.00	C.Y.
301002	GABC, PATCHING	3.00	C.Y.
401029	SUPERPAVE TYPE C, PG 64-22, PATCHING	2.00	TON
404001	BITUMINOUS CRACK AND JOINT SEALING LESS THAN 3/4-INCH WIDE	4.00	L.F.
701017	I.PCC CURB AND GUTTER, TYPE 1-6	40.00	L.F.
705001	PCC SIDEWALK, 4"	200.00	S.F.
710002	ADJUST WATER VALVE BOXES	3.00	EACH
762000	SAW CUTTING, BITUMINOUS CONCRETE	60.00	L.F.
762001	SAW CUTTING, CONCRETE, FULL DEPTH	47.00	L.F.
811001	FLAGGER, NEW CASTLE COUNTY	44.00	HOUR
811013	FLAGGER, NEW CASTLE COUNTY, OVERTIME	5.00	HOUR
908001	TOPSOIL	2.00	TON
908016	PERMANENT GRASS SEEDING, SUBDIVISION	10.00	S.Y.
908020	EROSION CONTROL BLANKET MULCH	10.00	S.Y.

DELAWARE DEPARTMENT OF TRANSPORTATION

CONTRACT T202503120

(CAD) PAGE 77 OF 84

CANAL

COMMUNITY TRANSPORTATION FUND, WILMINGTON, 2025

---

LOCATION 35 WILMINGTON - W. 37TH ST. FROM 510 W. 37TH ST. WILMINGTON TO 510 W. 37TH ST. WILMINGTON

LENGTH  
GENERAL IMPROVEMENTS  
SIDEWALK REPAIRS

COMMENTS:

---

MATERIAL ESTIMATE FOR LOCATION 35

202000	EXCAVATION AND EMBANKMENT	1.00	C.Y.
211001	REMOVAL OF PORTLAND CEMENT CONCRETE PAVEMENT, CURB AND SIDEWALK	18.00	S.Y.
301001	GABC	3.00	C.Y.
301002	GABC, PATCHING	1.00	C.Y.
401029	SUPERPAVE TYPE C, PG 64-22, PATCHING	3.00	TON
404001	BITUMINOUS CRACK AND JOINT SEALING LESS THAN 3/4-INCH WIDE	2.00	L.F.
701013	PCC CURB, TYPE 1-8	15.00	L.F.
705001	PCC SIDEWALK, 4"	125.00	S.F.
710002	ADJUST WATER VALVE BOXES	1.00	EACH
762000	SAW CUTTING, BITUMINOUS CONCRETE	23.00	L.F.
762001	SAW CUTTING, CONCRETE, FULL DEPTH	28.00	L.F.
811001	FLAGGER, NEW CASTLE COUNTY	24.00	HOUR
811013	FLAGGER, NEW CASTLE COUNTY, OVERTIME	4.00	HOUR
908001	TOPSOIL	1.00	TON
908016	PERMANENT GRASS SEEDING, SUBDIVISION	4.00	S.Y.
908020	EROSION CONTROL BLANKET MULCH	4.00	S.Y.





**DELAWARE DEPARTMENT OF TRANSPORTATION**

**CONTRACT T202503120**

**(CAD) PAGE 80 OF 84**

**CANAL**

**COMMUNITY TRANSPORTATION FUND, WILMINGTON, 2025**

**LOCATION 37                      WOODBROOK - COUNTRY CLUB DR FROM CORNWALL RD (CIHM) TO 408 COUNTRY CLUB DR (CIHM)**

**LENGTH      152.4000 m                                      500.0000 L.F.**

**GENERAL IMPROVEMENTS**

**2" MILL AND OVERLAY(CURB WHERE NECESSARY)**

**COMMENTS:**

**MATERIAL ESTIMATE FOR LOCATION 37**

<b>202000</b>	<b>EXCAVATION AND EMBANKMENT</b>	<b>11.00</b>	<b>C.Y.</b>
<b>211001</b>	<b>REMOVAL OF PORTLAND CEMENT CONCRETE PAVEMENT, CURB AND SIDEWALK</b>	<b>44.00</b>	<b>S.Y.</b>
<b>301001</b>	<b>GABC</b>	<b>3.00</b>	<b>C.Y.</b>
<b>301002</b>	<b>GABC, PATCHING</b>	<b>2.00</b>	<b>C.Y.</b>
<b>401005</b>	<b>SUPERPAVE TYPE C, PG 64-22 (CARBONATE STONE)</b>	<b>250.00</b>	<b>TON</b>
<b>401029</b>	<b>SUPERPAVE TYPE C, PG 64-22, PATCHING</b>	<b>25.00</b>	<b>TON</b>
<b>401030</b>	<b>SUPERPAVE TYPE B, PG 64-22, PATCHING</b>	<b>25.00</b>	<b>TON</b>
<b>401506</b>	<b>SPEED HUMP</b>	<b>30.00</b>	<b>L.F.</b>
<b>404001</b>	<b>BITUMINOUS CRACK AND JOINT SEALING LESS THAN 3/4-INCH WIDE</b>	<b>325.00</b>	<b>L.F.</b>
<b>602100</b>	<b>DRAINAGE INLET GRATE(S)</b>	<b>2.00</b>	<b>EACH</b>
<b>602101</b>	<b>DRAINAGE INLET FRAME(S)</b>	<b>1.00</b>	<b>EACH</b>
<b>602130</b>	<b>ADJUSTING AND REPAIRING EXISTING DRAINAGE INLET</b>	<b>3.00</b>	<b>EACH</b>
<b>602132</b>	<b>ADJUSTING AND REPAIRING EXISTING MANHOLE</b>	<b>2.00</b>	<b>EACH</b>
<b>701013</b>	<b>PCC CURB, TYPE 1-8</b>	<b>100.00</b>	<b>L.F.</b>
<b>701014</b>	<b>PCC CURB, TYPE 2</b>	<b>70.00</b>	<b>L.F.</b>
<b>705001</b>	<b>PCC SIDEWALK, 4"</b>	<b>28.00</b>	<b>S.F.</b>
<b>705002</b>	<b>PCC SIDEWALK, 6"</b>	<b>56.00</b>	<b>S.F.</b>
<b>760010</b>	<b>PAVEMENT MILLING, BITUMINOUS CONCRETE PAVEMENT</b>	<b>3,400.00</b>	<b>SY-IN</b>
<b>762000</b>	<b>SAW CUTTING, BITUMINOUS CONCRETE</b>	<b>255.00</b>	<b>L.F.</b>
<b>762001</b>	<b>SAW CUTTING, CONCRETE, FULL DEPTH</b>	<b>29.00</b>	<b>L.F.</b>
<b>811001</b>	<b>FLAGGER, NEW CASTLE COUNTY</b>	<b>164.00</b>	<b>HOUR</b>
<b>811013</b>	<b>FLAGGER, NEW CASTLE COUNTY, OVERTIME</b>	<b>19.00</b>	<b>HOUR</b>
<b>905004</b>	<b>INLET SEDIMENT CONTROL, DRAINAGE INLET</b>	<b>4.00</b>	<b>EACH</b>
<b>908001</b>	<b>TOPSOIL</b>	<b>7.00</b>	<b>TON</b>
<b>908016</b>	<b>PERMANENT GRASS SEEDING, SUBDIVISION</b>	<b>41.00</b>	<b>S.Y.</b>

**DELAWARE DEPARTMENT OF TRANSPORTATION**

**CONTRACT T202503120**

**(CAD) PAGE 81 OF 84**

**CANAL**

**COMMUNITY TRANSPORTATION FUND, WILMINGTON, 2025**

---

**LOCATION 37**                      **WOODBROOK - COUNTRY CLUB DR FROM CORNWALL RD (CIHM) TO 408  
COUNTRY CLUB DR (CIHM)**

**LENGTH**      152.4000 m                      500.0000 L.F.

**GENERAL IMPROVEMENTS**

2" MILL AND OVERLAY(CURB WHERE NECESSARY)

**COMMENTS:**

---

**MATERIAL ESTIMATE FOR LOCATION 37**

**908020      EROSION CONTROL BLANKET MULCH**

**41.00    S.Y.**

---

**DELAWARE DEPARTMENT OF TRANSPORTATION****CONTRACT T202503120****(CAD) PAGE 82 OF 84****CANAL****COMMUNITY TRANSPORTATION FUND, WILMINGTON, 2025**

---

**CONTRACT QUANTITIES SUMMARY SHEET**

202000	EXCAVATION AND EMBANKMENT	187.00	C.Y.
211001	REMOVAL OF PORTLAND CEMENT CONCRETE PAVEMENT, CURB AND SIDEWALK	2,234.00	S.Y.
211510	STUMP REMOVAL	2.00	L.F.
301001	GABC	192.00	C.Y.
301002	GABC, PATCHING	282.00	C.Y.
401005	SUPERPAVE TYPE C, PG 64-22 (CARBONATE STONE)	4,085.00	TON
401029	SUPERPAVE TYPE C, PG 64-22, PATCHING	942.00	TON
401030	SUPERPAVE TYPE B, PG 64-22, PATCHING	663.00	TON
401506	SPEED HUMP	138.00	L.F.
404001	BITUMINOUS CRACK AND JOINT SEALING LESS THAN 3/4-INCH WIDE	3,793.00	L.F.
501001	PCC PAVEMENT, 8"	58.00	S.Y.
602100	DRAINAGE INLET GRATE(S)	11.00	EACH
602101	DRAINAGE INLET FRAME(S)	7.00	EACH
602102	MANHOLE COVER(S)	1.00	EACH
602103	MANHOLE FRAME(S)	1.00	EACH
602130	ADJUSTING AND REPAIRING EXISTING DRAINAGE INLET	26.00	EACH
602131	ADJUSTING AND REPAIRING EXISTING DOUBLE DRAINAGE INLET	7.00	EACH
602132	ADJUSTING AND REPAIRING EXISTING MANHOLE	36.00	EACH
701010	PCC CURB, TYPE 1-2	25.00	L.F.
701013	PCC CURB, TYPE 1-8	397.00	L.F.
701014	PCC CURB, TYPE 2	70.00	L.F.
701017	I.PCC CURB AND GUTTER, TYPE 1-6	40.00	L.F.
701019	I.PCC CURB AND GUTTER, TYPE 2	4,160.00	L.F.
701501	RESET EXISTING STONE CURB	26.00	L.F.
705001	PCC SIDEWALK, 4"	6,177.00	S.F.
705002	PCC SIDEWALK, 6"	3,384.00	S.F.
705008	PEDESTRIAN CONNECTION, TYPE 1	840.00	S.F.
705009	PEDESTRIAN CONNECTION, TYPE 2, 3, AND/OR 4	7,200.00	S.F.

---

DELAWARE DEPARTMENT OF TRANSPORTATION

CONTRACT T202503120

(CAD) PAGE 83 OF 84

CANAL

COMMUNITY TRANSPORTATION FUND, WILMINGTON, 2025

---

CONTRACT QUANTITIES SUMMARY SHEET

705013	TRUNCATED DOME DETECTABLE WARNING SURFACE	360.00	S.F.
705504	BRICK AND/OR BLOCK SIDEWALK	200.00	S.F.
710002	ADJUST WATER VALVE BOXES	41.00	EACH
710370	STEEL CASING PIPE, 4"	20.00	L.F.
760010	PAVEMENT MILLING, BITUMINOUS CONCRETE PAVEMENT	57,000.00	SY-IN
760011	PAVEMENT MILLING, BITUMINOUS CONCRETE PAVEMENT, TAPER CUT	1,930.00	SY-IN
762000	SAW CUTTING, BITUMINOUS CONCRETE	7,755.00	L.F.
762001	SAW CUTTING, CONCRETE, FULL DEPTH	1,625.00	L.F.
763000	INITIAL EXPENSE/DE-MOBILIZATION	LUMP	SUM
801500	MAINTENANCE OF TRAFFIC, ALL INCLUSIVE	LUMP	SUM
802003	ARROW PANELS TYPE C	6.00	EA-DY
808002	PROVIDE AND MAINTAIN TRUCK MOUNTED ATTENUATOR, TYPE II	6.00	EA-DY
811001	FLAGGER, NEW CASTLE COUNTY	3,867.00	HOUR
811013	FLAGGER, NEW CASTLE COUNTY, OVERTIME	441.00	HOUR
817002	PERMANENT PAVEMENT STRIPING, SYMBOL/LEGEND, ALKYD-THERMOPLASTIC	820.00	S.F.
817003	TEMPORARY MARKINGS, PAINT, 4"	350.00	L.F.
817004	TEMPORARY MARKINGS, PAINT, SYMBOL/LEGEND	820.00	S.F.
817042	PERMANENT PAVEMENT STRIPING, EPOXY RESIN PAINT, WHITE/YELLOW, 6"	350.00	L.F.
819018	INSTALLATION OR REMOVAL OF TRAFFIC SIGN(S) ON SINGLE SIGN POST	2.00	EACH
819023	GALVANIZED TELESCOPING STEEL SIGNPOSTS, 15'X2", COMPLETE W/BASEPOSTS & HARDWARE	1.00	EACH
846001	PROVIDE AND INSTALL LOOP WIRE 1-CONDUCTOR #14 AWG ENCASED IN 1/4" FLEXIBLE TUBING IN A LOOP SAWCUT	220.00	L.F.
905004	INLET SEDIMENT CONTROL, DRAINAGE INLET	45.00	EACH
908001	TOPSOIL	337.00	TON
908016	PERMANENT GRASS SEEDING, SUBDIVISION	2,013.00	S.Y.
908020	EROSION CONTROL BLANKET MULCH	2,013.00	S.Y.

---

**DELAWARE DEPARTMENT OF TRANSPORTATION**

**CONTRACT T202503120**

**(CAD) PAGE 84 OF 84**

**CANAL**

**COMMUNITY TRANSPORTATION FUND, WILMINGTON, 2025**

---

**CONTRACT QUANTITIES SUMMARY SHEET**